

<input type="checkbox"/> PHOTOSTAKEN <input type="checkbox"/> SECONDARY CRASH <input type="checkbox"/> OH-2 <input type="checkbox"/> OH-1P <input type="checkbox"/> OTHER <input type="checkbox"/> PRIVATE PROPERTY	LOCAL INFORMATION REPORTING AGENCY NAME* City of Kent Police NCIC* 06703	2020-00015647 HIT/SKIP 1 - SOLVED 2 - UNSOLVED NUMBER OF UNITS 02 UNIT IN ERROR 98 - ANIMAL 99 - UNKNOWN 02
--	--	---

COUNTY* 67	LOCALITY* 1 - CITY 2 - VILLAGE 3 - TOWNSHIP 1	LOCATION: CITY, VILLAGE, TOWNSHIP* Kent	CRASH DATE / TIME* 09262020/1118	CRASH SEVERITY 1 - FATAL 2 - SERIOUS INJURY SUSPECTED 3 - MINOR INJURY SUSPECTED 4 - INJURY POSSIBLE 5 - PROPERTY DAMAGE ONLY 5
----------------------	--	---	--	--

ROUTE TYPE S R	ROUTE NUMBER 59	PREFIX 3	1 - NORTH 2 - SOUTH 3 - EAST 4 - WEST	LOCATION ROAD NAME MAIN	ROAD TYPE S T	LATITUDE DECIMAL DEGREES 41.153751
ROUTE TYPE	ROUTE NUMBER	PREFIX	1 - NORTH 2 - SOUTH 3 - EAST 4 - WEST	REFERENCE ROAD NAME (ROAD, MILEPOST, HOUSE #) LINCOLN	ROAD TYPE S T	LONGITUDE DECIMAL DEGREES -81.351300

REFERENCE POINT 1 - INTERSECTION 2 - MILE POST 3 - HOUSE # 1	DIRECTION FROM REFERENCE 1 - NORTH 2 - SOUTH 3 - EAST 4 - WEST 4	ROUTE TYPE IR - INTERSTATE ROUTE(TP) US - FEDERAL US ROUTE SR - STATE ROUTE CR - NUMBERED COUNTY ROUTE TR - NUMBERED TOWNSHIP ROUTE	ROAD TYPE AL - ALLEY AV - AVENUE BL - BOULEVARD CR - CIRCLE CT - COURT DR - DRIVE HE - HEIGHTS HW - HIGHWAY LA - LANE MP - MILEPOST OV - OVAL PK - PARKWAY PI - PIKE PL - PLACE RD - ROAD SQ - SQUARE ST - STREET TE - TERRACE TL - TRAIL WA - WAY	INTERSECTION RELATED <input checked="" type="checkbox"/> WITHIN INTERSECTION OR ON APPROACH <input type="checkbox"/> WITHIN INTERCHANGE AREA NUMBER OF APPROACHES 4
DISTANCE FROM REFERENCE 30	DISTANCE UNIT OF MEASURE 1 - MILES 2 - FEET 3 - YARDS 2	ROADWAY <input type="checkbox"/> ROADWAY DIVIDED		

LOCATION OF FIRST HARMFUL EVENT 1 - ON ROADWAY 2 - ON SHOULDER 3 - IN MEDIAN 4 - ON ROADSIDE 5 - ON GORE 6 - OUTSIDE TRAFFIC WAY 7 - ON RAMP 8 - OFF RAMP 01	9 - CROSSOVER 10 - DRIVEWAY/ALLEY ACCESS 11 - RAILWAY GRADE CROSSING 12 - SHARED USE PATHS OR TRAILS 13 - BIKE LANE 14 - TOLL BOOTH 99 - OTHER / UNKNOWN 2	MANNER OF CRASH COLLISION/IMPACT 1 - NOT COLLISION BETWEEN TWO MOTOR VEHICLES IN TRANSPORT 2 - REAR-END 3 - HEAD-ON 4 - REAR-TO-REAR 5 - BACKING 6 - ANGLE 7 - SIDESWIPE, SAME DIRECTION 8 - SIDESWIPE, OPPOSITE DIRECTION 9 - OTHER / UNKNOWN	DIRECTION OF TRAVEL 1 - NORTH 2 - SOUTH 3 - EAST 4 - WEST	MEDIAN TYPE 1 - DIVIDED FLUSH MEDIAN (<4 FEET) 2 - DIVIDED FLUSH MEDIAN (≥4 FEET) 3 - DIVIDED, DEPRESSED MEDIAN 4 - DIVIDED, RAISED MEDIAN (ANY TYPE) 9 - OTHER/UNKNOWN
--	--	---	---	--

<input type="checkbox"/> WORK ZONE RELATED <input type="checkbox"/> WORKERS PRESENT <input type="checkbox"/> LAW ENFORCEMENT PRESENT <input type="checkbox"/> ACTIVE SCHOOL ZONE	WORK ZONE TYPE 1 - LANE CLOSURE 2 - LANE SHIFT/CROSSOVER 3 - WORK ON SHOULDER OR MEDIAN 4 - INTERMITTENT OR MOVING WORK 5 - OTHER	LOCATION OF CRASH IN WORK ZONE 1 - BEFORE THE 1ST WORK ZONE WARNING SIGN 2 - ADVANCE WARNING AREA 3 - TRANSITION AREA 4 - ACTIVITY AREA 5 - TERMINATION AREA	CONTOUR 1 1 - STRAIGHT LEVEL 2 - STRAIGHT GRADE 3 - CURVE LEVEL 4 - CURVE GRADE 9 - OTHER/UNKNOWN	CONDITIONS 1 1 - DRY 2 - WET 3 - SNOW 4 - ICE 5 - SAND, MUD, DIRT, OIL, GRAVEL 6 - WATER (STANDING, MOVING) 7 - SLUSH 9 - OTHER/UNKNOWN	SURFACE 2 1 - CONCRETE 2 - BLACKTOP, BITUMINOUS, ASPHALT 3 - BRICK/BLOCK 4 - SLAG, GRAVEL, STONE 5 - DIRT 9 - OTHER/UNKNOWN
---	--	---	--	---	---

LIGHT CONDITION 1 - DAYLIGHT 2 - DAWN/DUSK 3 - DARK - LIGHTED ROADWAY 4 - DARK - ROADWAY NOT LIGHTED 5 - DARK - UNKNOWN ROADWAY LIGHTING 9 - OTHER / UNKNOWN 1	WEATHER 1 - CLEAR 2 - CLOUDY 3 - FOG, SMOG, SMOKE 4 - RAIN 5 - SLEET, HAIL 6 - SNOW 7 - SEVERE CROSSWINDS 8 - BLOWING SAND, SOIL, DIRT, SNOW 9 - FREEZING RAIN OR FREEZING DRIZZLE 99 - OTHER / UNKNOWN 01
--	--

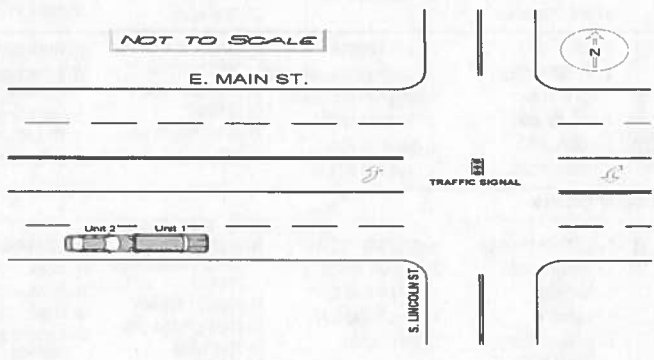
NARRATIVE UNIT ONE WAS STOPPED IN TRAFFIC EASTBOUND ON SR 59 BEFORE S. LINCOLN ST. UNIT TWO WAS TRAVELING BEHIND UNIT ONE AND FAILED TO STOP WITH AN ASSURED CLEAR DISTANCE. UNIT TWO STRUCK UNIT ONE. PROPERTY DAMAGE ONLY	Indicate the north direction with an "N" on the compass diagram.  
---	---

CRASH REPORTED DATE / TIME 09262020/1118	DISPATCH DATE / TIME 09262020/1132	ARRIVAL DATE / TIME 09262020/1140	SCENE CLEARED DATE / TIME 09262020/1200	REPORT TAKEN BY <input checked="" type="checkbox"/> POLICE AGENCY <input type="checkbox"/> MOTORIST
TOTAL TIME ROADWAY CLOSED 000	OTHER INVESTIGATION TIME 030	TOTAL MINUTES 058	OFFICER'S NAME* McNulty, Samantha S	CHECKED BY OFFICER'S NAME* Bowen, Jared
			OFFICER'S BADGE NUMBER* 236	CHECKED BY OFFICER'S BADGE NUMBER* 214

OWNER

VEHICLE

EVENT(S)

UNIT # 01 **OWNER NAME:** LAST, FIRST, MIDDLE (X SAME AS DRIVER) **FUSS, AARON, DAVID**
OWNER ADDRESS: STREET, CITY, STATE, ZIP (X SAME AS DRIVER) **3997 DARROW RD, Stow, OH 44224**
COMMERCIAL CARRIER: NAME, ADDRESS, CITY, STATE, ZIP _____ **COMMERCIAL CARRIER PHONE:** INCLUDE AREA CODE _____

LP STATE OH **LICENSE PLATE #** JBZ5911 **VEHICLE IDENTIFICATION #** 1D8GU28KX7W674444 **VEHICLE YEAR** 2007 **VEHICLE MAKE** Dodge
 INSURANCE VERIFIED **INSURANCE COMPANY** SAFECO **INSURANCE POLICY #** K3457447 **COLOR** BLK **VEHICLE MODEL** NITRO
 COMMERCIAL **GOVERNMENT** **IN EMERGENCY RESPONSE** **US DOT #** _____ **TOWED BY: COMPANY NAME** _____
 INTERLOCK DEVICE EQUIPPED **HIT/SKIP UNIT** **#OCCUPANTS** 01 **VEHICLE WEIGHT GVWR/GCWR**
 1 - <10K LBS
 2 - 10,001 - 26K LBS
 3 - >26K LBS
 MATERIAL RELEASED **PLACARD** **HAZARDOUS MATERIAL CLASS #** _____ **PLACARD ID #** _____

UNIT TYPE 01
 1 - PASSENGER CAR 7 - MOTORCYCLE 2-WHEELED 12 - GOLF CART 18 - LIMO (LIVERY VEHICLE) 23 - PEDESTRIAN / SKATER
 2 - PASSENGER VAN (MINIVAN) 8 - MOTORCYCLE 3-WHEELED 13 - SNOWMOBILE 19 - BUS (16+ PASSENGERS) 24 - WHEELCHAIR (ANY TYPE)
 3 - SPORT UTILITY VEHICLE 9 - AUTOCYCLE 14 - SINGLE UNIT TRUCK 20 - OTHER VEHICLE 25 - OTHER NON-MOTORIST
 4 - PICK UP 10 - MOPED OR MOTORIZED BICYCLE 15 - SEMI-TRACTOR 21 - HEAVY EQUIPMENT 26 - BICYCLE
 5 - CARGO VAN 11 - ALL TERRAIN VEHICLE (ATV / UTV) 16 - FARM EQUIPMENT 22 - ANIMAL WITH RIDER OR ANIMAL-DRAWN VEHICLE 27 - TRAIN
 6 - VAN (9-15 SEATS) 17 - MOTORHOME 99 - UNKNOWN OR HIT/SKIP

WAS VEHICLE OPERATING IN AUTONOMOUS MODE WHEN CRASH OCCURRED?
 1 - YES 2 - NO 9 - OTHER / UNKNOWN **AUTONOMOUS MODE LEVEL** 0
 0 - NO AUTOMATION 1 - DRIVER ASSISTANCE 3 - CONDITIONAL AUTOMATION 4 - HIGH AUTOMATION 5 - FULL AUTOMATION

SPECIAL FUNCTION 01
 1 - NONE 6 - BUS - CHARTER/TOUR 11 - FIRE 16 - FARM 21 - MAIL CARRIER
 2 - TAXI 7 - BUS - INTERCITY 12 - MILITARY 17 - MOWING 18 - SNOW REMOVAL
 3 - ELECTRONIC RIDE SHARING 8 - BUS - SHUTTLE 13 - POLICE 19 - TOWING
 4 - SCHOOL TRANSPORT 9 - BUS - OTHER 14 - PUBLIC UTILITY 20 - SAFETY SERVICE PATROL

CARGO BODY TYPE 01
 1 - NO CARGO BODY TYPE / NOT APPLICABLE 3 - VEHICLE TOWING ANOTHER MOTOR VEHICLE 5 - INTERMODAL CONTAINER CHASSIS 8 - POLE 12 - CONCRETE MIXER
 2 - BUS 4 - LOGGING 6 - CARGO VAN/ENCLOSED BOX 9 - CARGO TANK 13 - AUTO TRANSPORTER
 7 - GRAINCHIPS/GRAVEL 11 - DUMP 10 - FLAT BED 14 - GARBAGE/REFUSE 99 - OTHER / UNKNOWN

VEHICLE DEFECTS
 1 - TURN SIGNALS 4 - BRAKES 7 - WORN OR SLICK TIRES 9 - MOTOR TROUBLE 99 - OTHER / UNKNOWN
 2 - HEAD LAMPS 5 - STEERING 8 - TRAILER EQUIPMENT DEFECTIVE 10 - DISABLED FROM PRIOR ACCIDENT
 3 - TAIL LAMPS 6 - TIRE BLOWOUT

NON-MOTORIST LOCATION AT IMPACT
 1 - INTERSECTION - MARKED CROSSWALK 3 - INTERSECTION - OTHER 6 - BICYCLE LANE 9 - MEDIAN/CROSSING ISLAND 12 - FIRST RESPONDER AT INCIDENT SCENE
 2 - INTERSECTION - UNMARKED CROSSWALK 4 - MIDBLOCK - MARKED CROSSWALK 7 - SHOULDER / ROADSIDE 10 - DRIVEWAY ACCESS 11 - SHARED USE PATHS OR TRAILS 99 - OTHER / UNKNOWN
 5 - TRAVEL LANE - OTHER LOCATION 8 - SIDEWALK

ACTION 4 **PRE-CRASH ACTIONS** 11
 1 - NON-CONTACT 1 - STRAIGHT AHEAD 7 - MAKING U-TURN 13 - NEGOTIATING A CURVE 18 - APPROACHING OR LEAVING VEHICLE
 2 - NON-COLLISION 2 - BACKING 8 - ENTERING TRAFFIC LANE 14 - ENTERING OR CROSSING SPECIFIED LOCATION 19 - STANDING
 3 - STRIKING 3 - CHANGING LANES 9 - LEAVING TRAFFIC LANE 15 - WALKING, RUNNING, JOGGING, PLAYING 20 - OTHER NON-MOTORIST
 4 - STRUCK 4 - OVERTAKING/PASSING 10 - PARKED 16 - WORKING 21 - STANDING OUTSIDE DISABLED VEHICLE
 5 - BOTH STRIKING & STRUCK 5 - MAKING RIGHT TURN 11 - SLOWING OR STOPPED IN TRAFFIC 17 - PUSHING VEHICLE 99 - OTHER / UNKNOWN
 6 - MAKING LEFT TURN 12 - DR. VERLESS 22 - OTHER MOVABLE OBJECT

CONTRIBUTING CIRCUMSTANCES 01
 1 - NONE 7 - LEFT OF CENTER 13 - IMPROPER START FROM A PARKED POSITION 17 - VISION OBSTRUCTION 21 - LYING IN ROADWAY
 2 - FAILURE TO YIELD 8 - FOLLOWING TOO CLOSE / ACDA 14 - OPERATING DEFECTIVE EQUIPMENT 18 - OPERATING DEFECTIVE EQUIPMENT 22 - NOT DISCERNIBLE
 3 - RAN RED LIGHT 9 - IMPROPER LANE CHANGE 15 - STOPPED OR PARKED ILLEGALLY 19 - LOAD SHIFTING/FALLING/SPILLING 23 - OPENING DOOR INTO ROADWAY
 4 - RAN STOP SIGN 10 - IMPROPER PASSING 16 - WRONG WAY 20 - IMPROPER CROSSING 99 - OTHER IMPROPER ACTION
 5 - UNSAFE SPEED 11 - DROVE OFF ROAD 17 - VISION OBSTRUCTION 21 - LYING IN ROADWAY
 6 - IMPROPER TURN 12 - IMPROPER BACKING

SEQUENCE OF EVENTS
 1 20
 1 - OVERTURN/ROLLOVER 6 - EQUIPMENT FAILURE 11 - CROSS CENTERLINE - OPPOSITE DIRECTION OF TRAVEL 16 - RAILWAY VEHICLE 22 - WORK ZONE MAINTENANCE EQUIPMENT
 2 - FIRE/EXPLOSION 7 - SEPARATION OF UNITS 12 - DOWNHILL RUNAWAY 17 - ANIMAL - FARM 23 - STRUCK BY FALLING, SHIFTING CARGO OR ANYTHING SET IN MOTION BY A MOTOR VEHICLE
 3 - IMMERSION 8 - RAN OFF ROAD RIGHT 13 - OTHER NON-COLLISION 18 - ANIMAL - DEER 24 - OTHER MOVABLE OBJECT
 4 - JACKKNIFE 9 - RAN OFF ROAD LEFT 14 - PEDESTRIAN 19 - ANIMAL - OTHER
 5 - CARGO / EQUIPMENT LOSS OR SHIFT 10 - CROSS MEDIAN 15 - PEDESTRIAN 20 - MOTOR VEHICLE IN TRANSPORT
 6 - IMPROPER TURN 12 - IMPROPER BACKING

COLLISION WITH FIXED OBJECT - STRUCK
 25 - IMPACT ATTENUATOR / CRASH CUSHION 31 - GUARDRAIL END 37 - TRAFFIC SIGN POST 43 - CURB 50 - WORK ZONE MAINTENANCE EQUIPMENT
 26 - BRIDGE OVERHEAD STRUCTURE 32 - PORTABLE BARRIER 38 - OVERHEAD SIGN POST 44 - DITCH 51 - WALL
 27 - BRIDGE PIER OR ABUTMENT 33 - MEDIAN CABLE BARRIER 39 - LIGHT / LUMINARIES SUPPORT 45 - EMBANKMENT 52 - BUILDING
 28 - BRIDGE PARAPET 34 - MEDIAN GUARDRAIL BARRIER 40 - UTILITY POLE 46 - FENCE 53 - TUNNEL
 29 - BRIDGE RAIL 35 - MEDIAN CONCRETE BARRIER 41 - OTHER POST, POLE OR SUPPORT 47 - MAILBOX 54 - OTHER FIXED OBJECT
 30 - GUARDRAIL FACE 36 - MEDIAN OTHER BARRIER 42 - CULVERT 48 - TREE 99 - OTHER / UNKNOWN
 49 - FIRE HYDRANT

FIRST HARMFUL EVENT 1 **MOST HARMFUL EVENT** 1

LOCAL REPORT NUMBER
 2020-00015647

DAMAGE
DAMAGE SCALE
 2 1 - NONE 3 - FUNCTIONAL DAMAGE
 2 2 - MINOR DAMAGE 4 - DISABLING DAMAGE
 9 - UNKNOWN

DAMAGED AREA(S)
 INDICATE ALL THAT APPLY

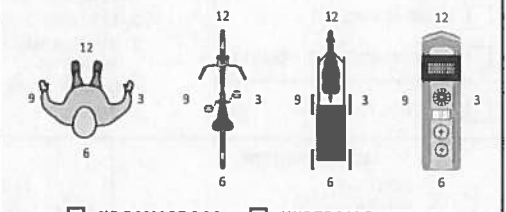
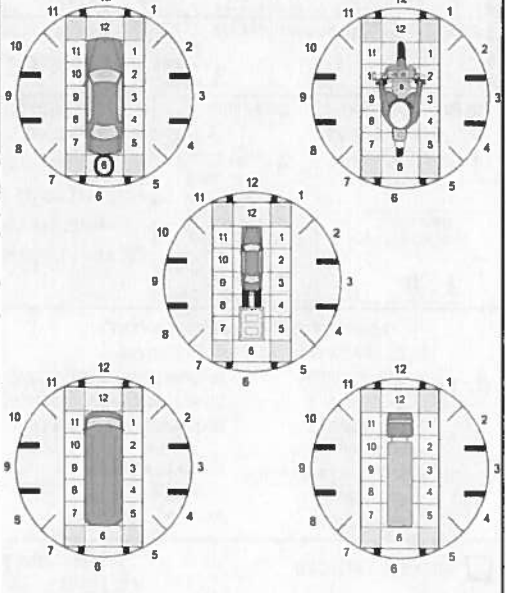

NO DAMAGE [0] **UNDERCARRIAGE** [14]
 TOP [13] **ALL AREAS** [15]
 UNIT NOT AT SCENE [16]

INITIAL POINT OF CONTACT
 0 - NO DAMAGE 14 - UNDERCARRIAGE
 1-12 - REFER TO UNIT DIAGRAM 15 - VEHICLE NOT AT SCENE
 13 - TOP 99 - UNKNOWN

TRAFFIC
TRAFFICWAY FLOW
 2 1 - ONE-WAY 2 - TWO-WAY
TRAFFIC CONTROL
 2 1 - ROUNDABOUT 4 - STOP SIGN
 2 - SIGNAL 5 - YIELD SIGN
 3 - FLASHER 6 - NO CONTROL

OF THROUGH LANES ON ROAD 4
RAIL GRADE CROSSING
 1 - NOT INVOLVED
 2 - INVOLVED-ACTIVE CROSSING
 3 - INVOLVED-PASSIVE CROSSING

UNIT / NON-MOTORIST DIRECTION
 FROM 4 TO 3
 1 - NORTH 5 - NORTH-EAST
 2 - SOUTH 6 - NORTH-WEST
 3 - EAST 7 - SOUTH-EAST
 4 - WEST 8 - SOUTH-WEST
 9 - OTHER / UNKNOWN

UNIT SPEED 000
POSTED SPEED 35
DETECTED SPEED 1
 1 - STATED / ESTIMATED SPEED
 2 - CALCULATED / EDR
 3 - UNDETERMINED

OWNER

UNIT # 02 OWNER NAME: LAST, FIRST, MIDDLE (SAME AS DRIVER) **CLIFFORD, CHERYL, ANN**

OWNER ADDRESS: STREET, CITY, STATE, ZIP (SAME AS DRIVER) **5427 WILSHIRE PARK DR, HUDSON, OH 44236**

COMMERCIAL CARRIER: NAME, ADDRESS, CITY, STATE, ZIP _____

OWNER PHONE: INCLUDE AREA CODE (SAME AS DRIVER) _____

COMMERCIAL CARRIER PHONE: INCLUDE AREA CODE _____

DAMAGE

DAMAGE SCALE

4 1 - NONE 3 - FUNCTIONAL DAMAGE
2 - MINOR DAMAGE 4 - DISABLING DAMAGE
9 - UNKNOWN

VEHICLE

LP STATE OH LICENSE PLATE # HGJ9986 VEHICLE IDENTIFICATION # 1G1PF5S99B7301908 VEHICLE YEAR 2011 VEHICLE MAKE Chevrolet

INSURANCE VERIFIED INSURANCE COMPANY STATEFARM INSURANCE POLICY # 957-253-C12-35A COLOR BLU VEHICLE MODEL CRUZE

COMMERCIAL GOVERNMENT IN EMERGENCY RESPONSE TYPE OF USE

INTERLOCK DEVICE EQUIPPED HIT/SKIP UNIT #OCCUPANTS 01 US DOT # _____ TOWED BY: COMPANY NAME _____ PARKED FOR PRIVATE TOW _____

HAZARDOUS MATERIAL CLASS # _____ PLACARD ID # _____

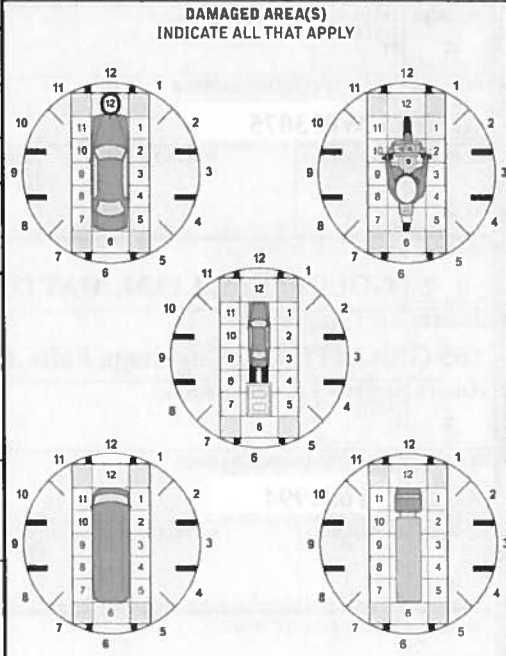

UNIT TYPE

01 1 - PASSENGER CAR 7 - MOTORCYCLE 2-WHEELED 12 - GOLF CART 18 - LIMO (LIVERY VEHICLE) 23 - PEDESTRIAN / SKATER
2 - PASSENGER VAN (MINIVAN) 8 - MOTORCYCLE 3-WHEELED 13 - SNOWMOBILE 19 - BUS (16+ PASSENGERS) 24 - WHEELCHAIR (ANY TYPE)
3 - SPORT UTILITY VEHICLE 9 - AUTOCYCLE 14 - SINGLE UNIT TRUCK 20 - OTHER VEHICLE 25 - OTHER NON-MOTORIST
4 - PICK UP 10 - MOPED OR MOTORIZED BICYCLE 15 - SEMI-TRACTOR 21 - HEAVY EQUIPMENT 26 - BICYCLE
5 - CARGO VAN 11 - ALL TERRAIN VEHICLE (ATV / UTV) 16 - FARM EQUIPMENT 22 - ANIMAL WITH RIDER OR ANIMAL-DRAWN VEHICLE 27 - TRAIN
6 - VAN (9-15 SEATS) 17 - MOTORHOME

OF TRAILING UNITS _____

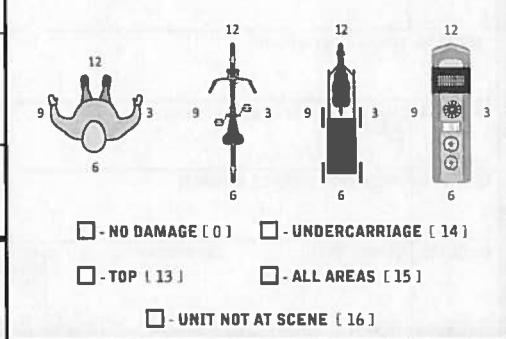

SPECIAL FUNCTION

01 1 - NONE 6 - BUS - CHARTER/TOUR 11 - FIRE 16 - FARM 21 - MAIL CARRIER
2 - TAXI 7 - BUS - INTERCITY 12 - MILITARY 17 - MOWING 99 - OTHER / UNKNOWN
3 - ELECTRONIC RIDE SHARING 8 - BUS - SHUTTLE 13 - POLICE 18 - SNOW REMOVAL
4 - SCHOOL TRANSPORT 9 - BUS - OTHER 14 - PUBLIC UTILITY 19 - TOWING
5 - BUS - TRANSIT/COMMUTER 10 - AMBULANCE 15 - CONSTRUCTION EQUIPMENT 20 - SAFETY SERVICE PATROL

CARGO BODY TYPE

01 1 - NO CARGO BODY TYPE / NOT APPLICABLE 3 - VEHICLE TOWING ANOTHER MOTOR VEHICLE 5 - INTERMODAL CONTAINER CHASSIS 8 - POLE 12 - CONCRETE MIXER
2 - BUS 4 - LOGGING 6 - CARGO VAN/ENCLOSED BOX 9 - CARGO TANK 13 - AUTO TRANSPORTER
7 - GRAIN/CHIPS/GRAVEL 10 - FLAT BED 11 - DUMP 14 - GARBAGE/REFUSE 99 - OTHER / UNKNOWN

VEHICLE DEFECTS

01 1 - TURN SIGNALS 4 - BRAKES 7 - WORN OR SLICK TIRES 9 - MOTOR TROUBLE 99 - OTHER / UNKNOWN
2 - HEAD LAMPS 5 - STEERING 8 - TRAILER EQUIPMENT DEFECTIVE 10 - DISABLED FROM PRIOR ACCIDENT
3 - TAIL LAMPS 6 - TIRE BLOWOUT

NON-MOTORIST LOCATION AT IMPACT

01 1 - INTERSECTION - MARKED CROSSWALK 3 - INTERSECTION - OTHER 6 - BICYCLE LANE 9 - MEDIAN/CROSSING ISLAND 12 - FIRST RESPONDER AT INCIDENT SCENE
2 - INTERSECTION - UNMARKED CROSSWALK 4 - MIDBLOCK - MARKED CROSSWALK 7 - SHOULDER / ROADSIDE 10 - DRIVEWAY ACCESS
5 - TRAVEL LANE - OTHER LOCATION 8 - SIDEWALK 11 - SHARED USE PATHS OR TRAILS 99 - OTHER / UNKNOWN

ACTION

3 1 - NON-CONTACT 1 - STRAIGHT AHEAD 7 - MAKING U-TURN 13 - NEGOTIATING A CURVE 18 - APPROACHING OR LEAVING VEHICLE
2 - NON-COLLISION 2 - BACKING 8 - ENTERING TRAFFIC LANE 14 - ENTERING OR CROSSING SPECIFIED LOCATION 19 - STANDING
3 - STRIKING 01 3 - CHANGING LANES 9 - LEAVING TRAFFIC LANE 15 - WALKING, RUNNING, JOGGING, PLAYING 20 - OTHER NON-MOTORIST
4 - STRUCK PRE-CRASH ACTIONS 4 - OVERTAKING/PASSING 10 - PARKED 16 - WORKING 21 - STANDING OUTSIDE DISABLED VEHICLE
5 - BOTH STRIKING & STRUCK 5 - MAKING RIGHT TURN 11 - SLOWING OR STOPPED IN TRAFFIC 17 - PUSHING VEHICLE 99 - OTHER / UNKNOWN
9 - OTHER / UNKNOWN 6 - MAKING LEFT TURN 12 - DR. VERLESS 99 - OTHER / UNKNOWN

INITIAL POINT OF CONTACT

12 0 - NO DAMAGE 14 - UNDERCARRIAGE
1-12 - REFER TO UNIT DIAGRAM 15 - VEHICLE NOT AT SCENE
13 - TOP 99 - UNKNOWN

CONTRIBUTING CIRCUMSTANCES

08 1 - NONE 7 - LEFT OF CENTER 13 - IMPROPER START FROM A PARKED POSITION 17 - VISION OBSTRUCTION 21 - LYING IN ROADWAY
2 - FAILURE TO YIELD 8 - FOLLOWING TOO CLOSE / ACDA 14 - STOPPED OR PARKED ILLEGALLY 18 - OPERATING DEFECTIVE EQUIPMENT 22 - NOT DISCERNIBLE
3 - RAN RED LIGHT 9 - IMPROPER LANE CHANGE 15 - SWERVING TO AVOID 19 - LOAD SHIFTING/FALLING/ SPILLING 23 - OPENING DOOR INTO ROADWAY
4 - RAN STOP SIGN 10 - IMPROPER PASSING 16 - WRONG WAY 20 - IMPROPER CROSSING 99 - OTHER IMPROPER ACTION
5 - UNSAFE SPEED 11 - DROVE OFF ROAD
6 - IMPROPER TURN 12 - IMPROPER BACKING

TRAFFIC

TRAFFICWAY FLOW

2 1 - ONE-WAY
2 - TWO-WAY

TRAFFIC CONTROL

2 1 - ROUNDABOUT 4 - STOP SIGN
2 - SIGNAL 5 - YIELD SIGN
3 - FLASHER 6 - NO CONTROL

SEQUENCE OF EVENTS

20 1 - OVERTURN/ROLLOVER 6 - EQUIPMENT FAILURE 11 - CROSS CENTERLINE - OPPOSITE DIRECTION OF TRAVEL 16 - RAILWAY VEHICLE 22 - WORK ZONE MAINTENANCE EQUIPMENT
2 - FIRE/EXP. OSION 7 - SEPARATION OF UNITS 12 - DOWNHILL RUNAWAY 17 - ANIMAL - FARM 23 - STRUCK BY FALLING, SHIFTING CARGO OR ANYTHING SET IN MOTION BY A MOTOR VEHICLE
3 - IMMERSION 8 - RAN OFF ROAD RIGHT 13 - OTHER NON-COLLISION 18 - ANIMAL - DEER 24 - OTHER MOVABLE OBJECT
4 - JACKKNIFE 9 - RAN OFF ROAD LEFT 14 - PEDESTRIAN 19 - ANIMAL - OTHER 20 - MOTOR VEHICLE IN TRANSPORT
5 - CARGO / EQUIPMENT LOSS OR SHIFT 10 - CROSS MEDIAN 15 - PEDALCYCLE 21 - PARKED MOTOR VEHICLE

OF THROUGH LANES ON ROAD

4

RAIL GRADE CROSSING

1 1 - NOT INVOLVED
2 - INVOLVED-ACTIVE CROSSING
3 - INVOLVED-PASSIVE CROSSING

COLLISION WITH FIXED OBJECT - STRUCK

1 25 - IMPACT ATTENUATOR / CRASH CUSHION 31 - GUARDRAIL END 37 - TRAFFIC SIGN POST 43 - CURB 50 - WORK ZONE MAINTENANCE EQUIPMENT
26 - BRIDGE OVERHEAD STRUCTURE 32 - PORTABLE BARRIER 38 - OVERHEAD SIGN POST 44 - DITCH 51 - WALL
27 - BRIDGE PIER OR ABUTMENT 33 - MEDIAN CABLE BARRIER 39 - LIGHT / LUMINARIES SUPPORT 45 - EMBANKMENT 52 - BUILDING
28 - BRIDGE PARAPET 34 - MEDIAN GUARDRAIL BARRIER 40 - UTILITY POLE 46 - FENCE 53 - TUNNEL
29 - BRIDGE RAIL 35 - MEDIAN CONCRETE BARRIER 41 - OTHER POST, POLE OR SUPPORT 47 - MAILBOX 54 - OTHER FIXED OBJECT
30 - GUARDRAIL FACE 36 - MEDIAN OTHER BARRIER 42 - CULVERT 48 - TREE 99 - OTHER / UNKNOWN
49 - FIRE HYDRANT

UNIT / NON-MOTORIST DIRECTION

FROM 4 TO 3

1 - NORTH 5 - NORTHEAST
2 - SOUTH 6 - NORTHWEST
3 - EAST 7 - SOUTHEAST
4 - WEST 8 - SOUTHWEST
9 - OTHER / UNKNOWN

UNIT SPEED

025

DETECTED SPEED

1 1 - STATED / ESTIMATED SPEED
2 - CALCULATED / EDR
3 - UNDETERMINED

POSTED SPEED

35

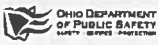

MOTORIST / Non-MOTORIST

LOCAL REPORT NUMBER
2,020-00015647

UNIT # 0, 1	NAME: LAST, FIRST, MIDDLE FUSS, AARON, DAVID				DATE OF BIRTH 0, 1, 2, 4, 1, 9, 8, 3		AGE 37	GENDER M	
ADDRESS: STREET, CITY, STATE, ZIP 3997 DARROW RD, Stow, OH 44224					CONTACT PHONE - INCLUDE AREA CODE				
INJURIES 5	INJURED TAKEN BY	EMS AGENCY (NAME)	INJURED TAKEN TO: MEDICAL FACILITY (NAME, CITY)	SAFETY EQUIPMENT USED 0, 4	<input type="checkbox"/> DOT-COMPLIANT MC HELMET	SEATING POSITION 0, 1	AIR BAG USAGE 1	EJECTION 1	TRAPPED 1
OL STATE O, H	OPERATOR LICENSE NUMBER		OFFENSE CHARGED	LOCAL CODE <input type="checkbox"/>	OFFENSE DESCRIPTION			CITATION NUMBER	
OL CLASS 4	ENDORSEMENT SELECT UP TO 2	RESTRICTION SELECT UP TO 3	DRIVER DISTRACTED BY 1	ALCOHOL / DRUG SUSPECTED <input type="checkbox"/> ALCOHOL <input type="checkbox"/> MARIJUANA <input type="checkbox"/> OTHER DRUG		CONDITION 1	ALCOHOL TEST STATUS TYPE VALUE STATUS TYPE RESULT SELECT UP TO 4 1 1 . 1 1		DRUG TEST(S) STATUS TYPE RESULT SELECT UP TO 4 1 1

UNIT # 0, 2	NAME: LAST, FIRST, MIDDLE GOLDSTEIN, LIAM, MATTHEW				DATE OF BIRTH 0, 4, 0, 9, 2, 0, 0, 1		AGE 19	GENDER M	
ADDRESS: STREET, CITY, STATE, ZIP 165 GRANITE DR, Cuyahoga Falls, OH 44264					CONTACT PHONE - INCLUDE AREA CODE				
INJURIES 5	INJURED TAKEN BY	EMS AGENCY (NAME)	INJURED TAKEN TO: MEDICAL FACILITY (NAME, CITY)	SAFETY EQUIPMENT USED 0, 4	<input type="checkbox"/> DOT-COMPLIANT MC HELMET	SEATING POSITION 0, 1	AIR BAG USAGE 1	EJECTION 1	TRAPPED 1
OL STATE O, H	OPERATOR LICENSE NUMBER		OFFENSE CHARGED 333.03	LOCAL CODE <input checked="" type="checkbox"/>	OFFENSE DESCRIPTION Maximum Speed Limits			CITATION NUMBER 60885	
OL CLASS 4	ENDORSEMENT SELECT UP TO 2	RESTRICTION SELECT UP TO 3	DRIVER DISTRACTED BY 1	ALCOHOL / DRUG SUSPECTED <input type="checkbox"/> ALCOHOL <input type="checkbox"/> MARIJUANA <input type="checkbox"/> OTHER DRUG		CONDITION 1	ALCOHOL TEST STATUS TYPE VALUE STATUS TYPE RESULT SELECT UP TO 4 1 1 . 1 1		DRUG TEST(S) STATUS TYPE RESULT SELECT UP TO 4 1 1

UNIT #	NAME: LAST, FIRST, MIDDLE				DATE OF BIRTH		AGE	GENDER	
ADDRESS: STREET, CITY, STATE, ZIP					CONTACT PHONE - INCLUDE AREA CODE				
INJURIES	INJURED TAKEN BY	EMS AGENCY (NAME)	INJURED TAKEN TO: MEDICAL FACILITY (NAME, CITY)	SAFETY EQUIPMENT USED	<input type="checkbox"/> DOT-COMPLIANT MC HELMET	SEATING POSITION	AIR BAG USAGE	EJECTION	TRAPPED
OL STATE	OPERATOR LICENSE NUMBER		OFFENSE CHARGED	LOCAL CODE <input type="checkbox"/>	OFFENSE DESCRIPTION			CITATION NUMBER	
OL CLASS	ENDORSEMENT SELECT UP TO 2	RESTRICTION SELECT UP TO 3	DRIVER DISTRACTED BY	ALCOHOL / DRUG SUSPECTED <input type="checkbox"/> ALCOHOL <input type="checkbox"/> MARIJUANA <input type="checkbox"/> OTHER DRUG		CONDITION	ALCOHOL TEST STATUS TYPE VALUE STATUS TYPE RESULT SELECT UP TO 4		DRUG TEST(S) STATUS TYPE RESULT SELECT UP TO 4

INJURIES	SEATING POSITION	AIR BAG	OL CLASS	OL RESTRICTION(S)	DRIVER DISTRACTION	TEST STATUS
1 - FATAL	1 - FRONT - LEFT SIDE (MOTORCYCLE DRIVER)	1 - NOT DEPLOYED	1 - CLASS A	1 - ALCOHOL INTERLOCK DEVICE	1 - NOT DISTRACTED	1 - NONE GIVEN
2 - SUSPECTED SERIOUS INJURY	2 - FRONT - MIDDLE	2 - DEPLOYED FRONT	2 - CLASS B	2 - CDL INTRASTATE ONLY	2 - MANUALLY OPERATING AN ELECTRONIC COMMUNICATION DEVICE (TEXTING, TYPING, DIALING)	2 - TEST REFUSED
3 - SUSPECTED MINOR INJURY	3 - FRONT - RIGHT SIDE	3 - DEPLOYED SIDE	3 - CLASS C	3 - CORRECTIVE LENSES	3 - TALKING ON HANDS-FREE COMMUNICATION DEVICE	3 - TEST GIVEN, CONTAMINATED SAMPLE / UNUSABLE
4 - POSSIBLE INJURY	4 - SECOND - LEFT SIDE (MOTORCYCLE PASSENGER)	4 - DEPLOYED BOTH FRONT / SIDE	4 - REGULAR CLASS (OHIO - D)	4 - FARM WAIVER	4 - TALKING ON HAND-HELD COMMUNICATION DEVICE	4 - TEST GIVEN, RESULTS KNOWN
5 - NO APPARENT INJURY	5 - SECOND - MIDDLE	5 - NOT APPLICABLE	5 - MC MOPED ONLY	5 - EXCEPT CLASS A BUS	5 - OTHER ACTIVITY WITH AN ELECTRONIC DEVICE	5 - TEST GIVEN, RESULTS UNKNOWN
INJURED TAKEN BY			EJECTION			ALCOHOL TEST TYPE
1 - NOT TRANSPORTED / TREATED AT SCENE	6 - SECOND - RIGHT SIDE	1 - NOT EJECTED	H - HAZMAT	6 - EXCEPT CLASS A & CLASS B BUS	6 - PASSENGER	1 - NONE
2 - EMS	7 - THIRD - LEFT SIDE (MOTORCYCLE SIDE CAR)	2 - PARTIALLY EJECTED	M - MOTORCYCLE	7 - EXCEPT TRACTOR-TRAILER	7 - OTHER DISTRACTION INSIDE THE VEHICLE	2 - BLOOD
3 - POLICE	8 - THIRD - MIDDLE	3 - TOTALLY EJECTED	P - PASSENGER	8 - INTERMEDIATE LICENSE RESTRICTIONS	8 - OTHER DISTRACTION OUTSIDE THE VEHICLE	3 - URINE
9 - OTHER / UNKNOWN	9 - THIRD - RIGHT SIDE	4 - NOT APPLICABLE	N - TANKER	9 - LEARNER'S PERMIT RESTRICTIONS	9 - OTHER / UNKNOWN	4 - BREATH
SAFETY EQUIPMENT			TRAPPED			DRUG TEST TYPE
1 - NONE USED	11 - PASSENGER IN OTHER ENCLOSED CARGO AREA (NON-TRAILING UNIT, BUS, PICK-UP WITH CAP)	1 - NOT TRAPPED	Q - MOTOR SCOOTER	10 - LIMITED TO DAYLIGHT ONLY	CONDITION	
2 - SHOULDER BELT ONLY USED	12 - PASSENGER IN UNENCLOSED CARGO AREA	2 - EXTRICATED BY MECHANICAL MEANS	R - THREE WHEEL MOTORCYCLE	11 - LIMITED TO EMPLOYMENT	1 - APPARENTLY NORMAL	2 - BLOOD
3 - LAP BELT ONLY USED	13 - TRAILING UNIT	3 - FREED BY NON-MECHANICAL MEANS	S - SCHOOL BUS	12 - LIMITED - OTHER	2 - PHYSICAL IMPAIRMENT	3 - URINE
4 - SHOULDER & LAP BELT USED	14 - RIDING ON VEHICLE EXTERIOR (NON-TRAILING UNIT)		T - DOUBLE & TRIPLE TRAILERS	13 - MECHANICAL DEVICES (SPECIAL BRAKES, HAND CONTROLS, OR OTHER ADAPTIVE DEVICES)	3 - EMOTIONAL (E.G., DEPRESSED, ANGRY, DISTURBED)	4 - OTHER
5 - CHILD RESTRAINT SYSTEM - FORWARD FACING	15 - NON-MOTORIST		X - TANKER / HAZMAT	14 - MILITARY VEHICLES ONLY	DRUG TEST RESULT(S)	
6 - CHILD RESTRAINT SYSTEM - REAR FACING	99 - OTHER / UNKNOWN			15 - MOTOR VEHICLES WITHOUT AIR BRAKES	4 - ILLNESS	1 - AMPHETAMINES
7 - BOOSTER SEAT				16 - OUTSIDE MIRROR	5 - FELL ASLEEP, FAINTED, FATIGUED, ETC.	2 - BARBITURATES
8 - HELMET USED				17 - PROSTHETIC AID	6 - UNDER THE INFLUENCE OF MEDICATIONS / DRUGS / ALCOHOL	3 - BENZODIAZEPINES
9 - PROTECTIVE PADS USED (ELBOW, KNEES, ETC.)				18 - OTHER	9 - OTHER / UNKNOWN	4 - CANNABINOIDS
10 - REFLECTIVE CLOTHING						5 - COCAINE
11 - LIGHTING - PEDESTRIAN / BICYCLE ONLY						6 - OPIATES / OPIOIDS
99 - OTHER / UNKNOWN						7 - OTHER
						8 - NEGATIVE RESULTS