



TRAFFIC CRASH REPORT

*DENOTES MANDATORY FIELD FOR SUPPLEMENT REPORT

LOCAL REPORT NUMBER*

PHOTOS TAKEN OH-2 OH-3
 SECONDARY CRASH OH-1P OTHER
 PRIVATE PROPERTY

LOCAL INFORMATION
 REPORTING AGENCY NAME* **City of Kent Police** NCIC* **06703**

2 0 2 2 - 0 0 0 2 0 0 9 5

HIT/SKIP
 1 - SOLVED **0 4**
 2 - UNSOLVED
 UNIT IN ERROR
 98 - ANIMAL **0 1**
 99 - UNKNOWN

COUNTY* **6 7** LOCALITY* **1** LOCATION: CITY, VILLAGE, TOWNSHIP* **Kent**

CRASH DATE / TIME* **12022022/0005** CRASH SEVERITY **5**

ROUTE TYPE **S R** ROUTE NUMBER **59** PREFIX **3** LOCATION ROAD NAME **MAIN** ROAD TYPE **S T**

LATITUDE DECIMAL DEGREES **41.153826**

ROUTE TYPE **S R** ROUTE NUMBER **59** PREFIX **3** REFERENCE ROAD NAME (ROAD, MILEPOST, HOUSE #) **805** ROAD TYPE **S T**

LONGITUDE DECIMAL DEGREES **-81.346797**

REFERENCE POINT
 1 - INTERSECTION **3**
 2 - MILE POST
 3 - HOUSE #
 DIRECTION FROM REFERENCE
 N - NORTH
 S - SOUTH
 E - EAST
 W - WEST
 ROUTE TYPE
 IR - INTERSTATE ROUTE (TP)
 US - FEDERAL US ROUTE
 SR - STATE ROUTE
 CR - CIRCLED COUNTY ROUTE
 TR - NUMBERED TOWNSHIP ROUTE
 ROAD TYPE
 AL - ALLEY HW - HIGHWAY RD - ROAD
 AV - AVENUE LA - LANE SQ - SQUARE
 BL - BOULEVARD MP - MILEPOST ST - STREET
 CR - CIRCLE OV - OVAL TE - TERRACE
 CT - COURT PK - PARKWAY TL - TRAIL
 DR - DRIVE PI - PIKE WA - WAY
 HE - HEIGHTS PL - PLACE

INTERSECTION RELATED
 WITHIN INTERSECTION OR ON APPROACH
 WITHIN INTERCHANGE AREA NUMBER OF APPROACHES
 ROADWAY
 ROADWAY DIVIDED

LOCATION OF FIRST HARMFUL EVENT
 1 - ON ROADWAY **0 1**
 2 - ON SHOULDER
 3 - IN MEDIAN
 4 - ON ROADSIDE
 5 - ON GORE
 6 - OUTSIDE TRAFFIC WAY
 7 - ON RAMP
 8 - OFF RAMP
 9 - CROSSOVER
 10 - DRIVEWAY/ALLEY ACCESS
 11 - RAILWAY GRADE CROSSING
 12 - SHARED USE PATHS OR TRAILS
 13 - BIKE LANE
 14 - TOLL BOOTH
 99 - OTHER / UNKNOWN

MANNER OF CRASH COLLISION/IMPACT
 1 - NOT COLLISION BETWEEN TWO MOTOR VEHICLES IN TRANSPORT **2**
 2 - REAR-END
 3 - HEAD-ON
 4 - REAR-TO-REAR
 5 - BACKING
 6 - ANGLE
 7 - SIDESWIPE, SAME DIRECTION
 8 - SIDESWIPE, OPPOSITE DIRECTION
 9 - OTHER / UNKNOWN

DIRECTION OF TRAVEL
 N - NORTH
 S - SOUTH
 E - EAST
 W - WEST
 MEDIAN TYPE
 1 - DIVIDED FLUSH MEDIAN (<4 FEET)
 2 - DIVIDED FLUSH MEDIAN (≥4 FEET)
 3 - DIVIDED, DEPRESSED MEDIAN
 4 - DIVIDED, RAISED MEDIAN (ANY TYPE)
 9 - OTHER/UNKNOWN

WORK ZONE RELATED
 WORKERS PRESENT
 LAW ENFORCEMENT PRESENT
 ACTIVE SCHOOL ZONE

WORK ZONE TYPE
 1 - LANE CLOSURE
 2 - LANE SHIFT/CROSSOVER
 3 - WORK ON SHOULDER OR MEDIAN
 4 - INTERMITTENT OR MOVING WORK
 5 - OTHER

LOCATION OF CRASH IN WORK ZONE
 1 - BEFORE THE 1ST WORK ZONE WARNING SIGN
 2 - ADVANCE WARNING AREA
 3 - TRANSITION AREA
 4 - ACTIVITY AREA
 5 - TERMINATION AREA

CONTOUR **1**
 1 - STRAIGHT LEVEL
 2 - STRAIGHT GRADE
 3 - CURVE LEVEL
 4 - CURVE GRADE
 9 - OTHER/UNKNOWN

CONDITIONS **1**
 1 - DRY
 2 - WET
 3 - SNOW
 4 - ICE
 5 - SAND, MUD, DIRT, OIL, GRAVEL
 6 - WATER (STANDING, MOVING)
 7 - SLUSH
 9 - OTHER/UNKNOWN

SURFACE **2**
 1 - CONCRETE
 2 - BLACKTOP, BITUMINOUS, ASPHALT
 3 - BRICK/BLOCK
 4 - SLAG, GRAVEL, STONE
 5 - DIRT
 9 - OTHER/UNKNOWN

LIGHT CONDITION
 1 - DAYLIGHT
 2 - DAWN/DUSK
 3 - DARK - LIGHTED ROADWAY **3**
 4 - DARK - ROADWAY NOT LIGHTED
 5 - DARK - UNKNOWN ROADWAY LIGHTING
 9 - OTHER / UNKNOWN

WEATHER
 1 - CLEAR
 2 - CLOUDY **0 1**
 3 - FOG, SMOG, SMOKE
 4 - RAIN
 5 - SLEET, HAIL
 6 - SNOW
 7 - SEVERE CROSSWINDS
 8 - BLOWING SAND, SOIL, DIRT, SNOW
 9 - FREEZING RAIN OR FREEZING DRIZZLE
 99 - OTHER / UNKNOWN

CONTOUR **1**
 1 - STRAIGHT LEVEL
 2 - STRAIGHT GRADE
 3 - CURVE LEVEL
 4 - CURVE GRADE
 9 - OTHER/UNKNOWN

NARRATIVE
UNIT 2, UNIT 3, AND UNIT 4 WERE STOPPED ON E. MAIN ST. IN FRONT OF 805 E. MAIN ST. UNIT 1 FAILED TO MAINTAIN AN ASSURED CLEAR DISTANCE AHEAD STRIKING UNIT 2. UNIT 2 WAS PUSHED INTO UNIT 3 AND UNIT 3 WAS PUSHED INTO UNIT 4. UNIT 1 WAS CHARGED WITH OVI AND ACDA.

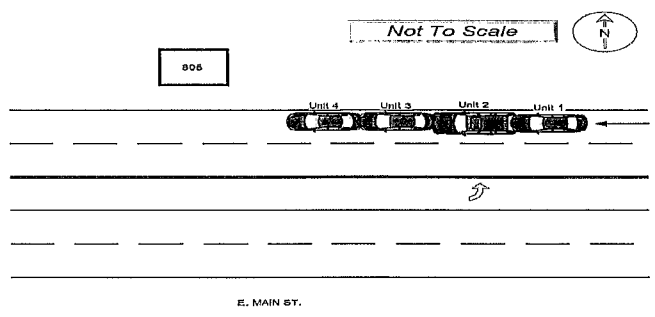
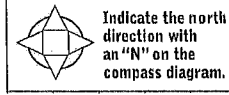

| | | | | | | | | | |
|--|--|--|--|---|--|---|---|---|--|
| CRASH REPORTED DATE / TIME 12022022/0005 | | DISPATCH DATE / TIME 12022022/0005 | | ARRIVAL DATE / TIME 12022022/0005 | | SCENE CLEARED DATE / TIME 12022022/0124 | | REPORT TAKEN BY <input checked="" type="checkbox"/> POLICE AGENCY <input type="checkbox"/> MOTORIST | |
| TOTAL TIME ROADWAY CLOSED 0 6 9 | OTHER INVESTIGATION TIME 0 3 0 | TOTAL MINUTES 1 0 9 | OFFICER'S NAME* Auckland, Kyle | | CHECKED BY OFFICER'S NAME* Nelson, Josh | | <input type="checkbox"/> SUPPLEMENT (CORRECTION OR ADDITION TO AN EXISTING REPORT SENT TO COPE) | | |
| | | | OFFICER'S BADGE NUMBER* 2 3 8 | | CHECKED BY OFFICER'S BADGE NUMBER* 2 3 2 | | | | |

OWNER

UNIT # 01 OWNER NAME: LAST, FIRST, MIDDLE (☐ SAME AS DRIVER)
SCHWARTZ, ANDREA, M

OWNER ADDRESS: STREET, CITY, STATE, ZIP (☐ SAME AS DRIVER)
21 FORBES RD, BEDFORD, OH 44146

COMMERCIAL CARRIER: NAME, ADDRESS, CITY, STATE, ZIP

OWNER PHONE: INCLUDE AREA CODE (☐ SAME AS DRIVER)

COMMERCIAL CARRIER PHONE: INCLUDE AREA CODE

DAMAGE

DAMAGE SCALE

3 1 - NONE 3 - FUNCTIONAL DAMAGE
 2 - MINOR DAMAGE 4 - DISABLING DAMAGE
 9 - UNKNOWN

VEHICLE

LP STATE OH LICENSE PLATE # HTW3374 VEHICLE IDENTIFICATION # 2B3KA43G66H301948 VEHICLE YEAR 2006 VEHICLE MAKE Dodge

INSURANCE VERIFIED INSURANCE COMPANY _____ INSURANCE POLICY # _____ COLOR BLU VEHICLE MODEL CHARGER

TYPE OF USE: COMMERCIAL GOVERNMENT IN EMERGENCY RESPONSE

US DOT # _____ TOWED BY: COMPANY NAME Bakers Towing

HAZARDOUS MATERIAL: MATERIAL RELEASED PLACARD CLASS # _____ PLACARD ID # _____

VEHICLE WEIGHT GVWR/GCWR: 1 - ≤10K LBS., 2 - 10,001 - 26K LBS., 3 - >26K LBS.

UNIT TYPE: 01 1 - PASSENGER CAR 7 - MOTORCYCLE 2-WHEELED 12 - GOLF CART 18 - LIMO (LIVERY VEHICLE) 23 - PEDESTRIAN / SKATER
 2 - PASSENGER VAN (MINIVAN) 8 - MOTORCYCLE 3-WHEELED 13 - SNOWMOBILE 19 - BUS (16+ PASSENGERS) 24 - WHEELCHAIR (ANY TYPE)
 3 - SPORT UTILITY VEHICLE 9 - AUTOCYCLE 14 - SINGLE UNIT TRUCK 20 - OTHER VEHICLE 25 - OTHER NON-MOTORIST
 4 - PICK UP 10 - MOPED OR MOTORIZED BICYCLE 15 - SEMI-TRACTOR 21 - HEAVY EQUIPMENT 26 - BICYCLE
 5 - CARGO VAN 11 - ALL TERRAIN VEHICLE (ATV/UTV) 16 - FARM EQUIPMENT 22 - ANIMAL WITH RIDER OR ANIMAL-DRAWN VEHICLE 27 - TRAIN
 6 - VAN (9-15 SEATS) 17 - MOTORHOME 99 - UNKNOWN OR HITS/SKIP

OF TRAILING UNITS _____

WAS VEHICLE OPERATING IN AUTONOMOUS MODE WHEN CRASH OCCURRED? 2 1 - YES 2 - NO 9 - OTHER / UNKNOWN AUTONOMOUS MODE LEVEL: 0 0 - NO AUTOMATION 1 - DRIVER ASSISTANCE 2 - PARTIAL AUTOMATION 3 - CONDITIONAL AUTOMATION 4 - HIGH AUTOMATION 5 - FULL AUTOMATION 9 - UNKNOWN

SPECIAL FUNCTION: 01 1 - NONE 6 - BUS - CHARTER/TOUR 11 - FIRE 16 - FARM 21 - MAIL CARRIER
 2 - TAXI 7 - BUS - INTERCITY 12 - MILITARY 17 - MOWING 99 - OTHER / UNKNOWN
 3 - ELECTRONIC RIDE SHARING 8 - BUS - SHUTTLE 13 - POLICE 18 - SNOW REMOVAL
 4 - SCHOOL TRANSPORT 9 - BUS - OTHER 14 - PUBLIC UTILITY 19 - TOWING
 5 - BUS - TRANSIT/COMMUTER 10 - AMBULANCE 15 - CONSTRUCTION EQUIPMENT 20 - SAFETY SERVICE PATROL

CARGO BODY TYPE: 01 1 - NO CARGO BODY TYPE / NOT APPLICABLE 3 - VEHICLE TOWING ANOTHER MOTOR VEHICLE 5 - INTERMODAL CONTAINER CHASSIS 8 - POLE 12 - CONCRETE MIXER
 2 - BUS 4 - LOGGING 6 - CARGO VAN/ENCLOSED BOX 9 - CARGO TANK 13 - AUTO TRANSPORTER
 7 - GRAIN/CHIPS/GRAVEL 10 - FLAT BED 11 - DUMP 14 - GARBAGE/REFUSE 99 - OTHER / UNKNOWN

VEHICLE DEFECTS: 1 - TURN SIGNALS 4 - BRAKES 7 - WORN OR SLICK TIRES 9 - MOTOR TROUBLE 99 - OTHER / UNKNOWN
 2 - HEAD LAMPS 5 - STEERING 8 - TRAILER EQUIPMENT DEFECTIVE 10 - DISABLED FROM PRIOR ACCIDENT
 3 - TAIL LAMPS 6 - TIRE BLOWOUT

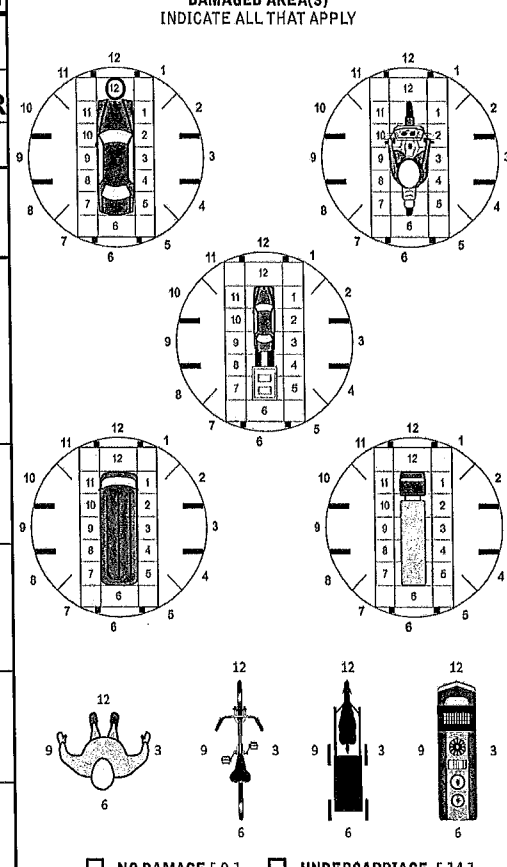

NON-MOTORIST LOCATION AT IMPACT: 1 - INTERSECTION - MARKED CROSSWALK 3 - INTERSECTION - OTHER 6 - BICYCLE LANE 9 - MEDIAN/CROSSING ISLAND 12 - FIRST RESPONDER AT INCIDENT SCENE
 2 - INTERSECTION - UNMARKED CROSSWALK 4 - MIDBLOCK - MARKED CROSSWALK 7 - SHOULDER / ROADSIDE 10 - DRIVEWAY ACCESS 13 - SHARED USE PATHS OR TRAILS 14 - OTHER / UNKNOWN
 5 - TRAVEL LANE - OTHER LOCATION 8 - SIDEWALK 11 - OTHER / UNKNOWN

ACTION: 3 1 - NON-CONTACT 1 - STRAIGHT AHEAD 7 - MAKING U-TURN 13 - NEGOTIATING A CURVE 18 - APPROACHING OR LEAVING VEHICLE
 2 - NON-COLLISION 2 - BACKING 8 - ENTERING TRAFFIC LANE 14 - ENTERING OR CROSSING SPECIFIED LOCATION 19 - STANDING
 3 - STRIKING 01 3 - CHANGING LANES 9 - LEAVING TRAFFIC LANE 15 - WALKING, RUNNING, JOGGING, PLAYING 20 - OTHER NON-MOTORIST
 4 - STRUCK PRE-CRASH ACTIONS 4 - OVERTAKING/PASSING 10 - PARKED 16 - WORKING 21 - STANDING OUTSIDE DISABLED VEHICLE
 5 - BOTH STRIKING & STRUCK 5 - MAKING RIGHT TURN 11 - SLOWING OR STOPPED IN TRAFFIC 17 - PUSHING VEHICLE 99 - OTHER / UNKNOWN
 6 - MAKING LEFT TURN 12 - DRIVERLESS 99 - OTHER / UNKNOWN
 9 - OTHER / UNKNOWN

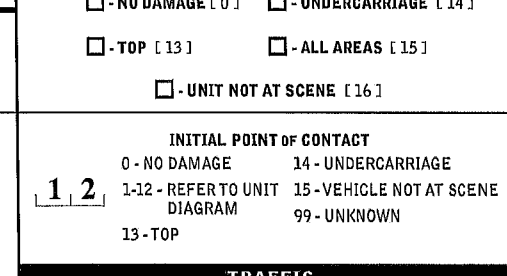

CONTRIBUTING CIRCUMSTANCES: 08 1 - NONE 7 - LEFT OF CENTER 13 - IMPROPER START FROM A PARKED POSITION 17 - VISION OBSTRUCTION 21 - LYING IN ROADWAY
 2 - FAILURE TO YIELD 8 - FOLLOWING TOO CLOSE / ACDA 14 - STOPPED OR PARKED ILLEGALLY 18 - OPERATING DEFECTIVE EQUIPMENT 22 - NOT DISCERNIBLE
 3 - RAN RED LIGHT 9 - IMPROPER LANE CHANGE 15 - STOPPED OR PARKED ILLEGALLY 19 - LOAD SHIFTING/FALLING/SPILLING 23 - OPENING DOOR INTO ROADWAY
 4 - RAN STOP SIGN 10 - IMPROPER PASSING 16 - WRONG WAY 20 - IMPROPER CROSSING 99 - OTHER IMPROPER ACTION
 5 - UNSAFE SPEED 11 - DROVE OFF ROAD 17 - SWERVING TO AVOID 21 - IMPROPER CROSSING
 6 - IMPROPER TURN 12 - IMPROPER BACKING

TRAFFIC

TRAFFICWAY FLOW: 2 1 - ONE-WAY 2 - TWO-WAY

TRAFFIC CONTROL: 6 1 - ROUNDABOUT 4 - STOP SIGN 2 - SIGNAL 5 - YIELD SIGN 3 - FLASHER 6 - NO CONTROL

OF THROUGH LANES ON ROAD: 4

RAIL GRADE CROSSING: 1 1 - NOT INVOLVED 2 - INVOLVED-ACTIVE CROSSING 3 - INVOLVED-PASSIVE CROSSING

EVENT(S)

SEQUENCE OF EVENTS: 1 2 0 1 - OVERTURN/ROLLOVER 6 - EQUIPMENT FAILURE 11 - CROSS CENTERLINE - OPPOSITE DIRECTION OF TRAVEL 16 - RAILWAY VEHICLE 22 - WORK ZONE MAINTENANCE EQUIPMENT
 2 - FIRE/EXPLOSION 7 - SEPARATION OF UNITS 12 - DOWNHILL RUNAWAY 17 - ANIMAL - FARM 23 - STRUCK BY FALLING, SHIFTING CARGO OR ANYTHING SET IN MOTION BY A MOTOR VEHICLE
 3 - IMMERSION 8 - RAN OFF ROAD RIGHT 13 - OTHER NON-COLLISION 18 - ANIMAL - DEER 24 - OTHER MOVABLE OBJECT
 4 - JACKKNIFE 9 - RAN OFF ROAD LEFT 14 - PEDESTRIAN 19 - ANIMAL - OTHER 20 - MOTOR VEHICLE IN TRANSPORT
 5 - CARGO / EQUIPMENT LOSS OR SHIFT 10 - CROSS MEDIAN 15 - PEDALCYCLE 21 - PARKED MOTOR VEHICLE

COLLISION WITH FIXED OBJECT - STRUCK

25 - IMPACT ATTENUATOR / CRASH CUSHION 31 - GUARDRAIL END 37 - TRAFFIC SIGN POST 43 - CURB 50 - WORK ZONE MAINTENANCE EQUIPMENT
 26 - BRIDGE OVERHEAD STRUCTURE 32 - PORTABLE BARRIER 38 - OVERHEAD SIGN POST 44 - DITCH 51 - WALL
 27 - BRIDGE PIER OR ABUTMENT 33 - MEDIAN CABLE BARRIER 39 - LIGHT / LUMINARIES SUPPORT 45 - EMBANKMENT 52 - BUILDING
 28 - BRIDGE PARAPET 34 - MEDIAN GUARDRAIL BARRIER 40 - UTILITY POLE 46 - FENCE 53 - TUNNEL
 29 - BRIDGE RAIL 35 - MEDIAN CONCRETE BARRIER 41 - OTHER POST, POLE OR SUPPORT 47 - MAILBOX 54 - OTHER FIXED OBJECT
 30 - GUARDRAIL FACE 36 - MEDIAN OTHER BARRIER 42 - CULVERT 48 - TREE 55 - OTHER / UNKNOWN
 49 - FIRE HYDRANT

FIRST HARMFUL EVENT: 1 MOST HARMFUL EVENT: 1

UNIT / NON-MOTORIST DIRECTION: FROM 3 TO 4

1 - NORTH 5 - NORTHEAST
 2 - SOUTH 6 - NORTHWEST
 3 - EAST 7 - SOUTHEAST
 4 - WEST 8 - SOUTHWEST
 9 - OTHER / UNKNOWN

UNIT SPEED: 0 2 5

POSTED SPEED: 3 5

DETECTED SPEED: 1 1 - STATED / ESTIMATED SPEED 2 - CALCULATED / EDR 3 - UNDETERMINED

OWNER
 UNIT # 0 2 OWNER NAME: LAST, FIRST, MIDDLE (SAME AS DRIVER) **CUNNINGHAM, ALICIA, MARIE**
 OWNER ADDRESS: STREET, CITY, STATE, ZIP (SAME AS DRIVER)
437 WELLESLEY AVE, CINCINNATI, OH 45224
 COMMERCIAL CARRIER: NAME, ADDRESS, CITY, STATE, ZIP _____
 COMMERCIAL CARRIER PHONE: INCLUDE AREA CODE _____

DAMAGE
 DAMAGE SCALE
2 1 - NONE 3 - FUNCTIONAL DAMAGE
 2 - MINOR DAMAGE 4 - DISABLING DAMAGE
 9 - UNKNOWN

VEHICLE
 LP STATE OH LICENSE PLATE # 058ZPM VEHICLE IDENTIFICATION # 2 GNDL73 F276078519 VEHICLE YEAR 2007 VEHICLE MAKE **Chevrolet**
 INSURANCE VERIFIED INSURANCE COMPANY **USAA** INSURANCE POLICY # **CIC0149213907102** COLOR **WHI** VEHICLE MODEL **EQUINOX**
 COMMERCIAL TYPE OF USE GOVERNMENT IN EMERGENCY RESPONSE US DOT # _____ TOWED BY: COMPANY NAME _____
 INTERLOCK DEVICE EQUIPPED HIT/SKIP UNIT #OCCUPANTS 0 5 VEHICLE WEIGHT GVWR/GCWR
 1 - <10K LBS.
 2 - 10,001 - 26K LBS.
 3 - >26K LBS.
 HAZARDOUS MATERIAL MATERIAL RELEASED CLASS # _____ PLACARD ID # _____
 PLACARD _____

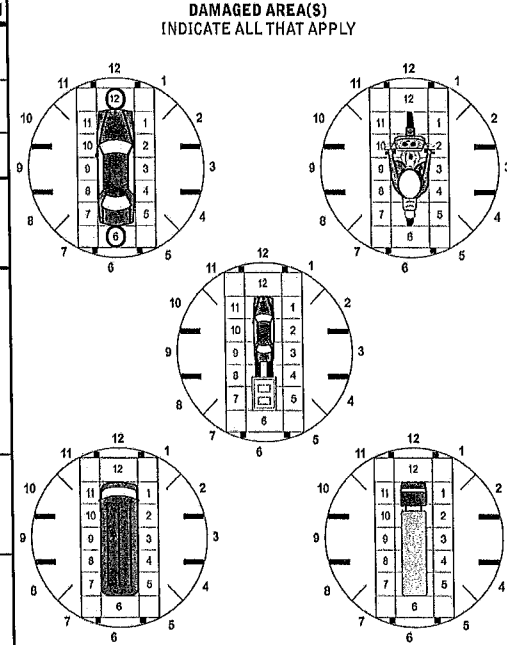

UNIT TYPE
0 3 1 - PASSENGER CAR 7 - MOTORCYCLE 2-WHEELED 12 - GOLF CART 18 - LIMO (LIVERY VEHICLE) 23 - PEDESTRIAN / SKATER
 2 - PASSENGER VAN (MINIVAN) 8 - MOTORCYCLE 3-WHEELED 13 - SNOWMOBILE 19 - BUS (16+ PASSENGERS) 24 - WHEELCHAIR (ANY TYPE)
 3 - SPORT UTILITY VEHICLE 9 - AUTOCYCLE 14 - SINGLE UNIT TRUCK 20 - OTHER VEHICLE 25 - OTHER NON-MOTORIST
 4 - PICK UP 10 - MOPED OR MOTORIZED BICYCLE 15 - SEMI-TRACTOR 21 - HEAVY EQUIPMENT 26 - BICYCLE
 5 - CARGO VAN 11 - ALL TERRAIN VEHICLE (ATV / UTV) 16 - FARM EQUIPMENT 22 - ANIMAL WITH RIDER OR ANIMAL-DRAWN VEHICLE 27 - TRAIN
 6 - VAN (9-15 SEATS) 17 - MOTORHOME 99 - UNKNOWN OR HITSKIP
 # OF TRAILING UNITS _____

WAS VEHICLE OPERATING IN AUTONOMOUS MODE WHEN CRASH OCCURRED?
2 1 - YES 2 - NO 9 - OTHER / UNKNOWN AUTONOMOUS MODE LEVEL 0
 0 - NO AUTOMATION 3 - CONDITIONAL AUTOMATION 9 - UNKNOWN
 1 - DRIVER ASSISTANCE 4 - HIGH AUTOMATION
 2 - PARTIAL AUTOMATION 5 - FULL AUTOMATION

SPECIAL FUNCTION
0 1 1 - NONE 6 - BUS - CHARTER/TOUR 11 - FIRE 16 - FARM 21 - MAIL CARRIER
 2 - TAXI 7 - BUS - INTERCITY 12 - MILITARY 17 - MOWING 99 - OTHER / UNKNOWN
 3 - ELECTRONIC RIDE SHARING 8 - BUS - SHUTTLE 13 - POLICE 18 - SNOW REMOVAL
 4 - SCHOOL TRANSPORT 9 - BUS - OTHER 14 - PUBLIC UTILITY 19 - TOWING
 5 - BUS - TRANSIT/COMMUTER 10 - AMBULANCE 15 - CONSTRUCTION EQUIPMENT 20 - SAFETY SERVICE PATROL

CARGO BODY TYPE
0 1 1 - NO CARGO BODY TYPE / NOT APPLICABLE 3 - VEHICLE TOWING ANOTHER MOTOR VEHICLE 5 - INTERMODAL CONTAINER CHASSIS 8 - POLE 12 - CONCRETE MIXER
 2 - BUS 4 - LOGGING 6 - CARGO VAN/ENCLOSED BOX 9 - CARGO TANK 13 - AUTO TRANSPORTER
 7 - GRAIN/CHIPS/GRAVEL 10 - FLAT BED 14 - GARBAGE/REFUSE 99 - OTHER / UNKNOWN
 11 - DUMP

VEHICLE DEFECTS
 1 - TURN SIGNALS 4 - BRAKES 7 - WORN OR SLICK TIRES 9 - MOTOR TROUBLE 99 - OTHER / UNKNOWN
 2 - HEAD LAMPS 5 - STEERING 8 - TRAILER EQUIPMENT DEFECTIVE 10 - DISABLED FROM PRIOR ACCIDENT
 3 - TAIL LAMPS 6 - TIRE BLOWOUT

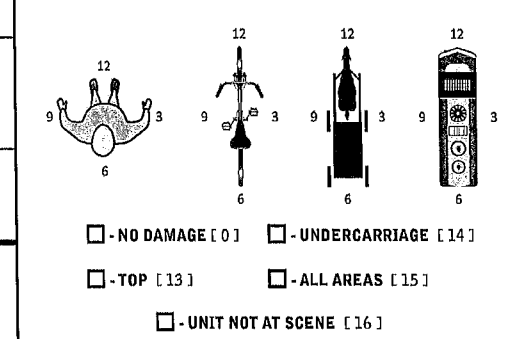

NON-MOTORIST LOCATION AT IMPACT
 1 - INTERSECTION - MARKED CROSSWALK 3 - INTERSECTION - OTHER 6 - BICYCLE LANE 9 - MEDIAN/CROSSING ISLAND 12 - FIRST RESPONDER AT INCIDENT SCENE
 2 - INTERSECTION - UNMARKED CROSSWALK 4 - MIDBLOCK - MARKED CROSSWALK 7 - SHOULDER / ROADSIDE 10 - DRIVEWAY ACCESS 14 - GARBAGE/REFUSE
 8 - SIDEWALK 11 - SHARED USE PATHS OR TRAILS 99 - OTHER / UNKNOWN
 5 - TRAVEL LANE - OTHER LOCATION

ACTION
5 1 - NON-CONTACT 1 - STRAIGHT AHEAD 7 - MAKING U-TURN 13 - NEGOTIATING A CURVE 18 - APPROACHING OR LEAVING VEHICLE
 2 - NON-COLLISION 2 - BACKING 8 - ENTERING TRAFFIC LANE 14 - ENTERING OR CROSSING SPECIFIED LOCATION 19 - STANDING
 3 - STRIKING 1 1 3 - CHANGING LANES 9 - LEAVING TRAFFIC LANE 15 - WALKING, RUNNING, JOGGING, PLAYING 20 - OTHER NON-MOTORIST
 4 - STRUCK PRE-CRASH ACTIONS 4 - OVERTAKING/PASSING 10 - PARKED 16 - WORKING 21 - STANDING OUTSIDE DISABLED VEHICLE
 5 - BOTH STRIKING & STRUCK 5 - MAKING RIGHT TURN 11 - SLOWING OR STOPPED IN TRAFFIC 17 - PUSHING VEHICLE 99 - OTHER / UNKNOWN
 6 - MAKING LEFT TURN 12 - DRIVERLESS
 9 - OTHER / UNKNOWN

INITIAL POINT OF CONTACT
0 6 0 - NO DAMAGE 14 - UNDERCARRIAGE
 1-12 - REFER TO UNIT DIAGRAM 15 - VEHICLE NOT AT SCENE
 13 - TOP 99 - UNKNOWN

CONTRIBUTING CIRCUMSTANCES
0 1 1 - NONE 7 - LEFT OF CENTER 13 - IMPROPER START FROM A PARKED POSITION 17 - VISION OBSTRUCTION 21 - LYING IN ROADWAY
 2 - FAILURE TO YIELD 8 - FOLLOWING TOO CLOSE / ACDA 14 - STOPPED OR PARKED ILLEGALLY 18 - OPERATING DEFECTIVE EQUIPMENT 22 - NOT DISCERNIBLE
 3 - RAN RED LIGHT 9 - IMPROPER LANE CHANGE 15 - SWERVING TO AVOID 19 - LOAD SHIFTING/FALLING/SPILLING 23 - OPENING DOOR INTO ROADWAY
 4 - RAN STOP SIGN 10 - IMPROPER PASSING 16 - WRONG WAY 20 - IMPROPER CROSSING 99 - OTHER IMPROPER ACTION
 5 - UNSAFE SPEED 11 - DROVE OFF ROAD
 6 - IMPROPER TURN 12 - IMPROPER BACKING

TRAFFIC
TRAFFICWAY FLOW
2 1 - ONE-WAY
 2 - TWO-WAY
TRAFFIC CONTROL
6 1 - ROUNDABOUT 4 - STOP SIGN
 2 - SIGNAL 5 - YIELD SIGN
 3 - FLASHER 6 - NO CONTROL

SEQUENCE OF EVENTS
1 2 0 1 - OVERTURN/ROLLOVER 6 - EQUIPMENT FAILURE 11 - CROSS CENTERLINE - OPPOSITE DIRECTION OF TRAVEL 16 - RAILWAY VEHICLE 22 - WORK ZONE MAINTENANCE EQUIPMENT
 2 - FIRE/EXPLOSION 7 - SEPARATION OF UNITS 12 - DOWNHILL RUNAWAY 17 - ANIMAL - FARM 23 - STRUCK BY FALLING, SHIFTING CARGO OR ANYTHING SET IN MOTION BY A MOTOR VEHICLE
 3 - IMMERSION 8 - RAN OFF ROAD RIGHT 13 - OTHER NON-COLLISION 18 - ANIMAL - DEER 24 - OTHER MOVABLE OBJECT
 4 - JACKKNIFE 9 - RAN OFF ROAD LEFT 14 - PEDESTRIAN 19 - ANIMAL - OTHER 20 - MOTOR VEHICLE IN TRANSPORT
 5 - CARGO / EQUIPMENT LOSS OR SHIFT 10 - CROSS MEDIAN 15 - PEDALCYCLE 21 - PARKED MOTOR VEHICLE

OF THROUGH LANES ON ROAD
4
RAIL GRADE CROSSING
1 1 - NOT INVOLVED
 2 - INVOLVED-ACTIVE CROSSING
 3 - INVOLVED-PASSIVE CROSSING

COLLISION WITH FIXED OBJECT - STRUCK
 25 - IMPACT ATTENUATOR / CRASH CUSHION 31 - GUARDRAIL END 37 - TRAFFIC SIGN POST 43 - CURB
 26 - BRIDGE OVERHEAD STRUCTURE 32 - PORTABLE BARRIER 38 - OVERHEAD SIGN POST 44 - DITCH
 27 - BRIDGE PIER OR ABUTMENT 33 - MEDIAN CABLE BARRIER 39 - LIGHT / LUMINARIES SUPPORT 45 - EMBANKMENT
 28 - BRIDGE PARAPET 34 - MEDIAN GUARDRAIL BARRIER 40 - UTILITY POLE 46 - FENCE
 29 - BRIDGE RAIL 35 - MEDIAN CONCRETE BARRIER 41 - OTHER POST, POLE OR SUPPORT 47 - MAILBOX
 30 - GUARDRAIL FACE 36 - MEDIAN OTHER BARRIER 42 - CULVERT 48 - TREE
 49 - FIRE HYDRANT 50 - WORK ZONE MAINTENANCE EQUIPMENT
 51 - WALL
 52 - BUILDING
 53 - TUNNEL
 54 - OTHER FIXED OBJECT
 99 - OTHER / UNKNOWN

UNIT / NON-MOTORIST DIRECTION
 FROM 3 TO 4
 1 - NORTH 5 - NORTHEAST
 2 - SOUTH 6 - NORTHWEST
 3 - EAST 7 - SOUTHEAST
 4 - WEST 8 - SOUTHWEST
 9 - OTHER / UNKNOWN

FIRST HARMFUL EVENT 1 **MOST HARMFUL EVENT** 1

UNIT SPEED
0 0 0
POSTED SPEED
3 5
DETECTED SPEED
1 1 - STATED / ESTIMATED SPEED
 2 - CALCULATED / EDR
 3 - UNDETERMINED

OWNER

UNIT # **0 3** OWNER NAME: LAST, FIRST, MIDDLE (SAME AS DRIVER) **MARTIN, KIMBERLY, L**
 OWNER ADDRESS: STREET, CITY, STATE, ZIP (SAME AS DRIVER) **4390 BALDWIN RD, PERRY, OH 44081**
 COMMERCIAL CARRIER: NAME, ADDRESS, CITY, STATE, ZIP _____ COMMERCIAL CARRIER PHONE: INCLUDE AREA CODE _____

DAMAGE

DAMAGE SCALE
2 1 - NONE 3 - FUNCTIONAL DAMAGE
 2 - MINOR DAMAGE 4 - DISABLING DAMAGE
 9 - UNKNOWN

VEHICLE

LP STATE **OH** LICENSE PLATE # **GVD7760** VEHICLE IDENTIFICATION # **2G2WR554X71155246** VEHICLE YEAR **2007** VEHICLE MAKE **Pontiac**
 INSURANCE VERIFIED INSURANCE COMPANY **STATE FARM** INSURANCE POLICY # **9344176E2935** COLOR **TAN** VEHICLE MODEL **GRAND AM**
 COMMERCIAL TYPE OF USE GOVERNMENT IN EMERGENCY RESPONSE US DOT # _____ TOWED BY: COMPANY NAME _____
 INTERLOCK DEVICE EQUIPPED HIT/SKIP UNIT #OCCUPANTS **0 1** VEHICLE WEIGHT GVWR/GCWR 1 - ≤10K LBS. 2 - 10,001 - 26K LBS. 3 - >26K LBS. HAZARDOUS MATERIAL MATERIAL RELEASED PLACARD CLASS # PLACARD ID # _____

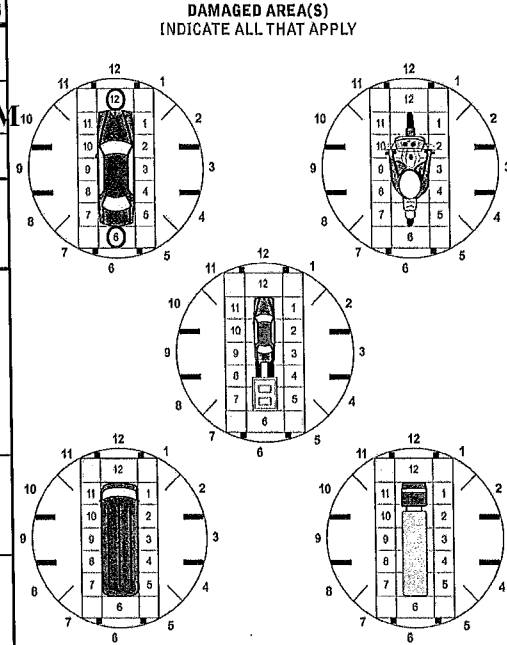

UNIT TYPE **0 1**
 1 - PASSENGER CAR 7 - MOTORCYCLE 2-WHEELED 12 - GOLF CART 18 - LIMO (LIVERY VEHICLE) 23 - PEDESTRIAN / SKATER
 2 - PASSENGER VAN (MINIVAN) 8 - MOTORCYCLE 3-WHEELED 13 - SNOWMOBILE 19 - BUS (16+ PASSENGERS) 24 - WHEELCHAIR (ANY TYPE)
 3 - SPORT UTILITY VEHICLE 9 - AUTOCYCLE 14 - SINGLE UNIT TRUCK 20 - OTHER VEHICLE 25 - OTHER NON-MOTORIST
 4 - PICK UP 10 - MOPED OR MOTORIZED BICYCLE 15 - SEMI-TRACTOR 21 - HEAVY EQUIPMENT 26 - BICYCLE
 5 - CARGO VAN 11 - ALL TERRAIN VEHICLE (ATV / UTV) 16 - FARM EQUIPMENT 22 - ANIMAL WITH RIDER OR ANIMAL-DRAWN VEHICLE 27 - TRAIN
 6 - VAN (9-15 SEATS) 17 - MOTORHOME 99 - UNKNOWN OR HITSKIP

OF TRAILING UNITS _____

WAS VEHICLE OPERATING IN AUTONOMOUS MODE WHEN CRASH OCCURRED? **2** 1 - YES 2 - NO 9 - OTHER / UNKNOWN AUTONOMOUS MODE LEVEL **0** 0 - NO AUTOMATION 1 - DRIVER ASSISTANCE 2 - PARTIAL AUTOMATION 3 - CONDITIONAL AUTOMATION 4 - HIGH AUTOMATION 5 - FULL AUTOMATION 9 - UNKNOWN

SPECIAL FUNCTION **0 1**
 1 - NONE 6 - BUS - CHARTER/TOUR 11 - FIRE 16 - FARM 21 - MAIL CARRIER
 2 - TAXI 7 - BUS - INTERCITY 12 - MILITARY 17 - MOWING 99 - OTHER / UNKNOWN
 3 - ELECTRONIC RIDE SHARING 8 - BUS - SHUTTLE 13 - POLICE 18 - SNOW REMOVAL
 4 - SCHOOL TRANSPORT 9 - BUS - OTHER 14 - PUBLIC UTILITY 19 - TOWING
 5 - BUS - TRANSIT/COMMUTER 10 - AMBULANCE 15 - CONSTRUCTION EQUIPMENT 20 - SAFETY SERVICE PATROL

CARGO BODY TYPE **0 1**
 1 - NO CARGO BODY TYPE / NOT APPLICABLE 3 - VEHICLE TOWING ANOTHER MOTOR VEHICLE 5 - INTERMODAL CONTAINER CHASSIS 8 - POLE 12 - CONCRETE MIXER
 2 - BUS 4 - LOGGING 6 - CARGO VAN/ENCLOSED BOX 9 - CARGO TANK 13 - AUTO TRANSPORTER
 7 - GRAIN/CHIPS/GRAVEL 11 - DUMP 14 - GARBAGE/REFUSE 99 - OTHER / UNKNOWN

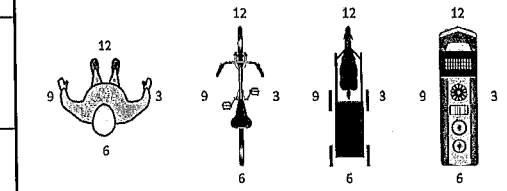

VEHICLE DEFECTS **0 1**
 1 - TURN SIGNALS 4 - BRAKES 7 - WORN OR SLICK TIRES 9 - MOTOR TROUBLE 99 - OTHER / UNKNOWN
 2 - HEAD LAMPS 5 - STEERING 8 - TRAILER EQUIPMENT DEFECTIVE 10 - DISABLED FROM PRIOR ACCIDENT
 3 - TAIL LAMPS 6 - TIRE BLOWOUT

- NO DAMAGE [0] - UNDERCARRIAGE [14]
 - TOP [13] - ALL AREAS [15]
 - UNIT NOT AT SCENE [16]

NON-MOTORIST LOCATION AT IMPACT _____
 1 - INTERSECTION - MARKED CROSSWALK 3 - INTERSECTION - OTHER 6 - BICYCLE LANE 9 - MEDIAN/CROSSING ISLAND 12 - FIRST RESPONDER AT INCIDENT SCENE
 2 - INTERSECTION - UNMARKED CROSSWALK 4 - MIDLICK - MARKED CROSSWALK 7 - SHOULDER / ROADSIDE 10 - DRIVEWAY ACCESS 99 - OTHER / UNKNOWN
 5 - TRAVEL LANE - OTHER LOCATION 8 - SIDEWALK 11 - SHARED USE PATHS OR TRAILS

ACTION **5** PRE-CRASH ACTIONS **1 1**
 1 - NON-CONTACT 2 - NON-COLLISION 3 - STRIKING 4 - STRUCK 5 - BOTH STRIKING & STRUCK 9 - OTHER / UNKNOWN
 1 - STRAIGHT AHEAD 2 - BACKING 3 - CHANGING LANES 4 - OVERTAKING/PASSING 5 - MAKING RIGHT TURN 6 - MAKING LEFT TURN
 7 - MAKING U-TURN 8 - ENTERING TRAFFIC LANE 9 - LEAVING TRAFFIC LANE 10 - PARKED 11 - SLOWING OR STOPPED IN TRAFFIC 12 - DRIVERLESS
 13 - NEGOTIATING A CURVE 14 - ENTERING OR CROSSING SPECIFIED LOCATION 15 - WALKING, RUNNING, JOGGING, PLAYING 16 - WORKING 17 - PUSHING VEHICLE
 18 - APPROACHING OR LEAVING VEHICLE 19 - STANDING 20 - OTHER NON-MOTORIST 21 - STANDING OUTSIDE DISABLED VEHICLE 99 - OTHER / UNKNOWN

INITIAL POINT OF CONTACT **0 6**
 0 - NO DAMAGE 14 - UNDERCARRIAGE
 1-12 - REFER TO UNIT DIAGRAM 15 - VEHICLE NOT AT SCENE
 13 - TOP 99 - UNKNOWN

CONTRIBUTING CIRCUMSTANCES **0 1**
 1 - NONE 7 - LEFT OF CENTER 13 - IMPROPER START FROM A PARKED POSITION 17 - VISION OBSTRUCTION 21 - LYING IN ROADWAY
 2 - FAILURE TO YIELD 8 - FOLLOWING TOO CLOSE / ACDA 14 - STOPPED OR PARKED ILLEGALLY 18 - OPERATING DEFECTIVE EQUIPMENT 22 - NOT DISCERNIBLE
 3 - RAN RED LIGHT 9 - IMPROPER LANE CHANGE 15 - SWERVING TO AVOID 19 - LOAD SHIFTING/FALLING/SPILLING 23 - OPENING DOOR INTO ROADWAY
 4 - RAN STOP SIGN 10 - IMPROPER PASSING 16 - WRONG WAY 20 - IMPROPER CROSSING 99 - OTHER IMPROPER ACTION
 5 - UNSAFE SPEED 11 - DROVE OFF ROAD 12 - IMPROPER BACKING

TRAFFIC

TRAFFICWAY FLOW **2** 1 - ONE-WAY 2 - TWO-WAY

TRAFFIC CONTROL **6** 1 - ROUNDABOUT 4 - STOP SIGN 2 - SIGNAL 5 - YIELD SIGN 3 - FLASHER 6 - NO CONTROL

SEQUENCE OF EVENTS **1 2 0**
 1 - OVERTURN/ROLLOVER 2 - FIRE/EXPLOSION 3 - IMMERSION 4 - JACKKNIFE 5 - CARGO / EQUIPMENT LOSS OR SHIFT
 6 - EQUIPMENT FAILURE 7 - SEPARATION OF UNITS 8 - RAN OFF ROAD RIGHT 9 - RAN OFF ROAD LEFT 10 - CROSS MEDIAN
 11 - CROSS CENTERLINE - OPPOSITE DIRECTION OF TRAVEL 12 - DOWNHILL RUNAWAY 13 - OTHER NON-COLLISION 14 - PEDESTRIAN 15 - PEDALCYCLE
 16 - RAILWAY VEHICLE 17 - ANIMAL - FARM 18 - ANIMAL - DEER 19 - ANIMAL - OTHER 20 - MOTOR VEHICLE IN TRANSPORT 21 - PARKED MOTOR VEHICLE
 22 - WORK ZONE MAINTENANCE EQUIPMENT 23 - STRUCK BY FALLING, SHIFTING CARGO OR ANYTHING SET IN MOTION BY A MOTOR VEHICLE 24 - OTHER MOVABLE OBJECT

OF THROUGH LANES ON ROAD **4**

RAIL GRADE CROSSING **1**
 1 - NOT INVOLVED
 2 - INVOLVED-ACTIVE CROSSING
 3 - INVOLVED-PASSIVE CROSSING

COLLISION WITH FIXED OBJECT - STRUCK

25 - IMPACT ATTENUATOR / CRASH CUSHION 26 - BRIDGE OVERHEAD STRUCTURE 27 - BRIDGE PIER OR ABUTMENT 28 - BRIDGE PARAPET 29 - BRIDGE RAIL 30 - GUARDRAIL FACE
 31 - GUARDRAIL END 32 - PORTABLE BARRIER 33 - MEDIAN CABLE BARRIER 34 - MEDIAN GUARDRAIL BARRIER 35 - MEDIAN CONCRETE BARRIER 36 - MEDIAN OTHER BARRIER
 37 - TRAFFIC SIGN POST 38 - OVERHEAD SIGN POST 39 - LIGHT / LUMINARIES SUPPORT 40 - UTILITY POLE 41 - OTHER POST, POLE OR SUPPORT 42 - CULVERT
 43 - CURB 44 - DITCH 45 - EMBANKMENT 46 - FENCE 47 - MAILBOX 48 - TREE 49 - FIRE HYDRANT
 50 - WORK ZONE MAINTENANCE EQUIPMENT 51 - WALL 52 - BUILDING 53 - TUNNEL 54 - OTHER FIXED OBJECT 99 - OTHER / UNKNOWN

UNIT / NON-MOTORIST DIRECTION
 FROM **3** TO **4**
 1 - NORTH 5 - NORTHEAST
 2 - SOUTH 6 - NORTHWEST
 3 - EAST 7 - SOUTHEAST
 4 - WEST 8 - SOUTHWEST
 9 - OTHER / UNKNOWN

1 FIRST HARMFUL EVENT **1** MOST HARMFUL EVENT

UNIT SPEED **0 0 0**

POSTED SPEED **3 5**

DETECTED SPEED **1**
 1 - STATED / ESTIMATED SPEED
 2 - CALCULATED / EDR
 3 - UNDETERMINED

OWNER

UNIT # 0 4 OWNER NAME: LAST, FIRST, MIDDLE (SAME AS DRIVER)
HUNT, ROBERT, ALLEN

OWNER ADDRESS: STREET, CITY, STATE, ZIP (SAME AS DRIVER)
4846 CRANBERRY, CANTON, OH 44709

COMMERCIAL CARRIER: NAME, ADDRESS, CITY, STATE, ZIP

COMMERCIAL CARRIER PHONE: INCLUDE AREA CODE

DAMAGE

DAMAGE SCALE

2 1 - NONE 3 - FUNCTIONAL DAMAGE
 2 - MINOR DAMAGE 4 - DISABLING DAMAGE
 9 - UNKNOWN

VEHICLE

LP STATE OH LICENSE PLATE # HZE6525 VEHICLE IDENTIFICATION # 1G4HR57Y16U123224 VEHICLE YEAR 2006 VEHICLE MAKE Buick

INSURANCE VERIFIED INSURANCE COMPANY PROGRESSIVE INSURANCE POLICY # 941584960 COLOR SIL VEHICLE MODEL LUCERNE

COMMERCIAL TYPE OF USE GOVERNMENT IN EMERGENCY RESPONSE US DOT # _____ TOWED BY: COMPANY NAME _____

INTERLOCK DEVICE EQUIPPED HIT/SKIP UNIT #OCCUPANTS 0 1 VEHICLE WEIGHT GVWR/GCWR
 1 - <10K LBS.
 2 - 10,001 - 26K LBS.
 3 - >26K LBS.

HAZARDOUS MATERIAL CLASS # _____ PLACARD ID # _____

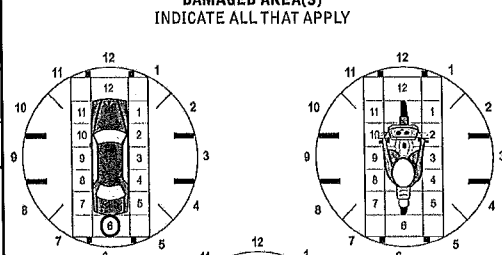

UNIT TYPE 0 1

1 - PASSENGER CAR 7 - MOTORCYCLE 2-WHEELED 12 - GOLF CART 18 - LIMO (LIVERY VEHICLE) 23 - PEDESTRIAN / SKATER
 2 - PASSENGER VAN (MINIVAN) 8 - MOTORCYCLE 3-WHEELED 13 - SNOWMOBILE 19 - BUS (16+ PASSENGERS) 24 - WHEELCHAIR (ANY TYPE)
 3 - SPORT UTILITY VEHICLE 9 - AUTOCYCLE 14 - SINGLE UNIT TRUCK 20 - OTHER VEHICLE 25 - OTHER NON-MOTORIST
 4 - PICK UP 10 - MOPED OR MOTORIZED BICYCLE 15 - SEMI-TRACTOR 21 - HEAVY EQUIPMENT 26 - BICYCLE
 5 - CARGO VAN 11 - ALL TERRAIN VEHICLE (ATV/UTV) 16 - FARM EQUIPMENT 22 - ANIMAL WITH RIDER OR ANIMAL-DRAWN VEHICLE 27 - TRAIN
 6 - VAN (9-15 SEATS) 17 - MOTORHOME 99 - UNKNOWN OR HITSKIP

OF TRAILING UNITS _____

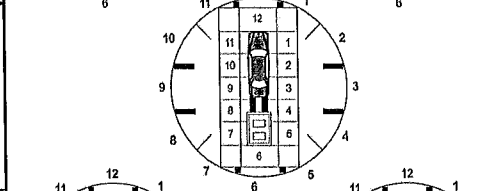

WAS VEHICLE OPERATING IN AUTONOMOUS MODE WHEN CRASH OCCURRED? 2

1 - YES 2 - NO 9 - OTHER / UNKNOWN

AUTONOMOUS MODE LEVEL 0

0 - NO AUTOMATION 3 - CONDITIONAL AUTOMATION 9 - UNKNOWN
 1 - DRIVER ASSISTANCE 4 - HIGH AUTOMATION
 2 - PARTIAL AUTOMATION 5 - FULL AUTOMATION

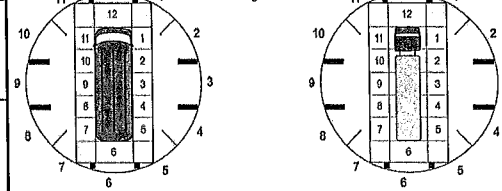

SPECIAL FUNCTION 0 1

1 - NONE 6 - BUS - CHARTER/TOUR 11 - FIRE 16 - FARM 21 - MAIL CARRIER
 2 - TAXI 7 - BUS - INTERCITY 12 - MILITARY 17 - MOWING 99 - OTHER / UNKNOWN
 3 - ELECTRONIC RIDE SHARING 8 - BUS - SHUTTLE 13 - POLICE 18 - SNOW REMOVAL
 4 - SCHOOL TRANSPORT 9 - BUS - OTHER 14 - PUBLIC UTILITY 19 - TOWING
 5 - BUS - TRANSIT/COMMUTER 10 - AMBULANCE 15 - CONSTRUCTION EQUIPMENT 20 - SAFETY SERVICE PATROL

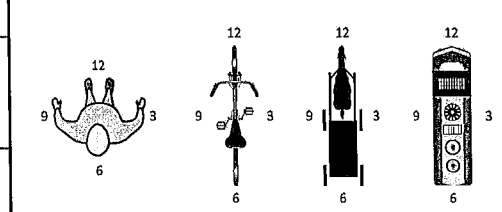

CARGO BODY TYPE 0 1

1 - NO CARGO BODY TYPE / NOT APPLICABLE 3 - VEHICLE TOWING ANOTHER MOTOR VEHICLE 5 - INTERMODAL CONTAINER CHASSIS 8 - POLE 12 - CONCRETE MIXER
 2 - BUS 4 - LOGGING 6 - CARGO VAN/ENCLOSED BOX 9 - CARGO TANK 13 - AUTO TRANSPORTER
 7 - GRAIN/CHIPS/GRAVEL 10 - FLAT BED 14 - GARBAGE/REFUSE
 11 - DUMP 99 - OTHER / UNKNOWN

- NO DAMAGE [0] - UNDERCARRIAGE [14]
 - TOP [13] - ALL AREAS [15]
 - UNIT NOT AT SCENE [16]

VEHICLE DEFECTS

1 - TURN SIGNALS 4 - BRAKES 7 - WORN OR SLICK TIRES 9 - MOTOR TROUBLE 99 - OTHER / UNKNOWN
 2 - HEAD LAMPS 5 - STEERING 8 - TRAILER EQUIPMENT DEFECTIVE 10 - DISABLED FROM PRIOR ACCIDENT
 3 - TAIL LAMPS 6 - TIRE BLOWOUT

NON-MOTORIST LOCATION AT IMPACT

1 - INTERSECTION - MARKED CROSSWALK 3 - INTERSECTION - OTHER 6 - BICYCLE LANE 9 - MEDIAN/CROSSING ISLAND 12 - FIRST RESPONDER AT INCIDENT SCENE
 2 - INTERSECTION - UNMARKED CROSSWALK 4 - MIDLICK - MARKED CROSSWALK 7 - SHOULDER / ROADSIDE 10 - DRIVEWAY ACCESS 99 - OTHER / UNKNOWN
 5 - TRAVEL LANE - OTHER LOCATION 8 - SIDEWALK 11 - SHARED USE PATHS OR TRAILS

INITIAL POINT OF CONTACT

0 6 0 - NO DAMAGE 14 - UNDERCARRIAGE
 1-12 - REFER TO UNIT DIAGRAM 15 - VEHICLE NOT AT SCENE
 99 - UNKNOWN
 13 - TOP

ACTION 4 PRE-CRASH ACTIONS 1 1

1 - NON-CONTACT 1 - STRAIGHT AHEAD 7 - MAKING U-TURN 13 - NEGOTIATING A CURVE 18 - APPROACHING OR LEAVING VEHICLE
 2 - NON-COLLISION 2 - BACKING 8 - ENTERING TRAFFIC LANE 14 - ENTERING OR CROSSING SPECIFIED LOCATION 19 - STANDING
 3 - STRIKING 3 - CHANGING LANES 9 - LEAVING TRAFFIC LANE 15 - WALKING, RUNNING, JOGGING, PLAYING 20 - OTHER NON-MOTORIST
 4 - STRUCK 4 - OVERTAKING/PASSING 10 - PARKED 16 - WORKING 21 - STANDING OUTSIDE DISABLED VEHICLE
 5 - BOTH STRIKING & STRUCK 5 - MAKING RIGHT TURN 11 - SLOWING OR STOPPED IN TRAFFIC 17 - PUSHING VEHICLE 99 - OTHER / UNKNOWN
 6 - MAKING LEFT TURN 12 - DRIVERLESS 99 - OTHER / UNKNOWN
 9 - OTHER / UNKNOWN

TRAFFIC

TRAFFICWAY FLOW 2 TRAFFIC CONTROL 6

1 - ONE-WAY 1 - ROUNDABOUT 4 - STOP SIGN
 2 - TWO-WAY 2 - SIGNAL 5 - YIELD SIGN
 3 - FLASHER 6 - NO CONTROL

CONTRIBUTING CIRCUMSTANCES 0 1

1 - NONE 7 - LEFT OF CENTER 13 - IMPROPER START FROM A PARKED POSITION 17 - VISION OBSTRUCTION 21 - LYING IN ROADWAY
 2 - FAILURE TO YIELD 8 - FOLLOWING TOO CLOSE / ACDA 14 - STOPPED OR PARKED ILLEGALLY 18 - OPERATING DEFECTIVE EQUIPMENT 22 - NOT DISCERNIBLE
 3 - RAN RED LIGHT 9 - IMPROPER LANE CHANGE 15 - SWERVING TO AVOID 19 - LOAD SHIFTING/FALLING/SPILLING 23 - OPENING DOOR INTO ROADWAY
 4 - RAN STOP SIGN 10 - IMPROPER PASSING 16 - WRONG WAY 20 - IMPROPER CROSSING 99 - OTHER IMPROPER ACTION
 5 - UNSAFE SPEED 11 - DROVE OFF ROAD
 6 - IMPROPER TURN 12 - IMPROPER BACKING

OF THROUGH LANES ON ROAD 4 RAIL GRADE CROSSING 1

1 - NOT INVOLVED
 2 - INVOLVED-ACTIVE CROSSING
 3 - INVOLVED-PASSIVE CROSSING

SEQUENCE OF EVENTS

1 2 0 1 - OVERTURN/ROLLOVER 6 - EQUIPMENT FAILURE 11 - CROSS CENTERLINE - OPPOSITE DIRECTION OF TRAVEL 16 - RAILWAY VEHICLE 22 - WORK ZONE MAINTENANCE EQUIPMENT
 2 - FIRE/EXPLOSION 7 - SEPARATION OF UNITS 12 - DOWNHILL RUNAWAY 17 - ANIMAL - FARM 23 - STRUCK BY FALLING, SHIFTING CARGO OR ANYTHING SET IN MOTION BY A MOTOR VEHICLE
 3 - IMMERSION 8 - RAN OFF ROAD RIGHT 13 - OTHER NON-COLLISION 18 - ANIMAL - DEER 24 - OTHER MOVABLE OBJECT
 4 - JACKKNIFE 9 - RAN OFF ROAD LEFT 14 - PEDESTRIAN 19 - ANIMAL - OTHER 20 - MOTOR VEHICLE IN TRANSPORT
 5 - CARGO / EQUIPMENT LOSS OR SHIFT 10 - CROSS MEDIAN 15 - PEDALCYCLE 21 - PARKED MOTOR VEHICLE

UNIT / NON-MOTORIST DIRECTION

FROM 3 TO 4

1 - NORTH 5 - NORTHEAST
 2 - SOUTH 6 - NORTHWEST
 3 - EAST 7 - SOUTHEAST
 4 - WEST 8 - SOUTHWEST
 9 - OTHER / UNKNOWN

COLLISION WITH FIXED OBJECT - STRUCK

4 25 - IMPACT ATTENUATOR / CRASH CUSHION 31 - GUARDRAIL END 37 - TRAFFIC SIGN POST 43 - CURB
5 26 - BRIDGE OVERHEAD STRUCTURE 32 - PORTABLE BARRIER 38 - OVERHEAD SIGN POST 44 - DITCH
6 27 - BRIDGE PIER OR ABUTMENT 33 - MEDIAN CABLE BARRIER 39 - LIGHT / LUMINARIES SUPPORT 45 - EMBANKMENT
 28 - BRIDGE PARAPET 34 - MEDIAN GUARDRAIL BARRIER 40 - UTILITY POLE 46 - FENCE
 29 - BRIDGE RAIL 35 - MEDIAN CONCRETE BARRIER 41 - OTHER POST, POLE OR SUPPORT 47 - MAILBOX
 30 - GUARDRAIL FACE 36 - MEDIAN OTHER BARRIER 42 - CULVERT 48 - TREE
 49 - FIRE HYDRANT

UNIT SPEED 0 0 0 DETECTED SPEED 1

1 - STATED / ESTIMATED SPEED
 2 - CALCULATED / EDR
 3 - UNDETERMINED

POSTED SPEED 3 5



MOTORIST / Non-MOTORIST

LOCAL REPORT NUMBER
2 0 2 2 - 0 0 0 2 0 0 9 5

| | | | | | | | | | |
|--|--|----------------------------|---|---|--|--------------------------------|---|----------------------|---|
| UNIT # 0 1 | NAME: LAST, FIRST, MIDDLE HERTEL, JACOB, CHARLES HENRY | | | | DATE OF BIRTH 1 0 3 1 2 0 0 1 | | AGE 2 1 | GENDER M | |
| ADDRESS: STREET, CITY, STATE, ZIP 87 NORDHAM DR, BEDFORD, OH 44146 | | | | | CONTACT PHONE - INCLUDE AREA CODE | | | | |
| INJURIES 5 | INJURED TAKEN BY | EMS AGENCY (NAME) | INJURED TAKEN TO: MEDICAL FACILITY (NAME, CITY) | SAFETY EQUIPMENT USED 0 4 | <input type="checkbox"/> DOT-COMPLIANT MC HELMET | SEATING POSITION 0 1 | AIR BAG USAGE 2 | EJECTION 1 | TRAPPED 1 |
| OL STATE O, H | OPERATOR LICENSE NUMBER | | OFFENSE CHARGED 4511.21A | LOCAL CODE <input type="checkbox"/> | OFFENSE DESCRIPTION Assured Clear Distan | | CITATION NUMBER 21295 | | |
| OL CLASS 4 | ENDORSEMENT SELECT UP TO 2 | RESTRICTION SELECT UP TO 3 | DRIVER DISTRACTED BY 1 | ALCOHOL / DRUG SUSPECTED <input checked="" type="checkbox"/> ALCOHOL <input type="checkbox"/> MARIJUANA <input type="checkbox"/> OTHER DRUG | | CONDITION 6 | ALCOHOL TEST STATUS 2 TYPE 1 VALUE | | DRUG TEST(S) STATUS 1 TYPE 1 RESULT SELECT UP TO 4 |

| | | | | | | | | | |
|---|--|----------------------------|---|--|--|--------------------------------|---|----------------------|---|
| UNIT # 0 2 | NAME: LAST, FIRST, MIDDLE BROWN, JAELYN, ELIZABETH | | | | DATE OF BIRTH 0 5 2 0 2 0 0 2 | | AGE 2 0 | GENDER F | |
| ADDRESS: STREET, CITY, STATE, ZIP 437 WELLESLEY AVE, CINCINNATI, OH 45224 | | | | | CONTACT PHONE - INCLUDE AREA CODE | | | | |
| INJURIES 5 | INJURED TAKEN BY | EMS AGENCY (NAME) | INJURED TAKEN TO: MEDICAL FACILITY (NAME, CITY) | SAFETY EQUIPMENT USED 0 4 | <input type="checkbox"/> DOT-COMPLIANT MC HELMET | SEATING POSITION 0 1 | AIR BAG USAGE 1 | EJECTION 1 | TRAPPED 1 |
| OL STATE O, H | OPERATOR LICENSE NUMBER | | OFFENSE CHARGED | LOCAL CODE <input type="checkbox"/> | OFFENSE DESCRIPTION | | CITATION NUMBER | | |
| OL CLASS 4 | ENDORSEMENT SELECT UP TO 2 | RESTRICTION SELECT UP TO 3 | DRIVER DISTRACTED BY 1 | ALCOHOL / DRUG SUSPECTED <input type="checkbox"/> ALCOHOL <input type="checkbox"/> MARIJUANA <input type="checkbox"/> OTHER DRUG | | CONDITION 1 | ALCOHOL TEST STATUS 1 TYPE 1 VALUE | | DRUG TEST(S) STATUS 1 TYPE 1 RESULT SELECT UP TO 4 |

| | | | | | | | | | |
|--|---|----------------------------|---|--|--|--------------------------------|---|----------------------|---|
| UNIT # 0 3 | NAME: LAST, FIRST, MIDDLE MARTIN, JOSHUA, ELI | | | | DATE OF BIRTH 0 2 2 9 2 0 0 0 | | AGE 2 2 | GENDER M | |
| ADDRESS: STREET, CITY, STATE, ZIP 4390 BALDWIN RD, PERRY, OH 44081 | | | | | CONTACT PHONE - INCLUDE AREA CODE | | | | |
| INJURIES 5 | INJURED TAKEN BY | EMS AGENCY (NAME) | INJURED TAKEN TO: MEDICAL FACILITY (NAME, CITY) | SAFETY EQUIPMENT USED 0 4 | <input type="checkbox"/> DOT-COMPLIANT MC HELMET | SEATING POSITION 0 1 | AIR BAG USAGE 1 | EJECTION 1 | TRAPPED 1 |
| OL STATE O, H | OPERATOR LICENSE NUMBER | | OFFENSE CHARGED | LOCAL CODE <input type="checkbox"/> | OFFENSE DESCRIPTION | | CITATION NUMBER | | |
| OL CLASS 4 | ENDORSEMENT SELECT UP TO 2 | RESTRICTION SELECT UP TO 3 | DRIVER DISTRACTED BY 1 | ALCOHOL / DRUG SUSPECTED <input type="checkbox"/> ALCOHOL <input type="checkbox"/> MARIJUANA <input type="checkbox"/> OTHER DRUG | | CONDITION 1 | ALCOHOL TEST STATUS 1 TYPE 1 VALUE | | DRUG TEST(S) STATUS 1 TYPE 1 RESULT SELECT UP TO 4 |

| INJURIES | SEATING POSITION | AIR BAG | OL CLASS | OL RESTRICTION(S) | DRIVER DISTRACTION | TEST STATUS |
|--|--|---|---|---|--|--|
| 1 - FATAL 2 - SUSPECTED SERIOUS INJURY 3 - SUSPECTED MINOR INJURY 4 - POSSIBLE INJURY 5 - NO APPARENT INJURY | 1 - FRONT - LEFT SIDE (MOTORCYCLE DRIVER) 2 - FRONT - MIDDLE 3 - FRONT - RIGHT SIDE 4 - SECOND - LEFT SIDE (MOTORCYCLE PASSENGER) 5 - SECOND - MIDDLE 6 - SECOND - RIGHT SIDE 7 - THIRD - LEFT SIDE (MOTORCYCLE SIDE CAR) 8 - THIRD - MIDDLE 9 - THIRD - RIGHT SIDE 10 - SLEEPER SECTION OF TRUCK CAB | 1 - NOT DEPLOYED 2 - DEPLOYED FRONT 3 - DEPLOYED SIDE 4 - DEPLOYED BOTH FRONT / SIDE 5 - NOT APPLICABLE 9 - DEPLOYMENT UNKNOWN | 1 - CLASS A 2 - CLASS B 3 - CLASS C 4 - REGULAR CLASS (OHIO = D) 5 - M/C MOPED ONLY 6 - NO VALID OL | 1 - ALCOHOL INTERLOCK DEVICE 2 - CDL INTRASTATE ONLY 3 - CORRECTIVE LENSES 4 - FARM WAIVER 5 - EXCEPT CLASS A BUS 6 - EXCEPT CLASS A & CLASS B BUS 7 - EXCEPT TRACTOR-TRAILER 8 - INTERMEDIATE LICENSE RESTRICTIONS 9 - LEARNER'S PERMIT RESTRICTIONS 10 - LIMITED TO DAYLIGHT ONLY 11 - LIMITED TO EMPLOYMENT 12 - LIMITED - OTHER 13 - MECHANICAL DEVICES (SPECIAL BRAKES, HAND CONTROLS, OR OTHER ADAPTIVE DEVICES) 14 - MILITARY VEHICLES ONLY 15 - MOTOR VEHICLES WITHOUT AIR BRAKES 16 - OUTSIDE MIRROR 17 - PROSTHETIC AID 18 - OTHER | 1 - NOT DISTRACTED 2 - MANUALLY OPERATING AN ELECTRONIC COMMUNICATION DEVICE (TEXTING, TYPING, DIALING) 3 - TALKING ON HANDS-FREE COMMUNICATION DEVICE 4 - TALKING ON HAND-HELD COMMUNICATION DEVICE 5 - OTHER ACTIVITY WITH AN ELECTRONIC DEVICE 6 - PASSENGER 7 - OTHER DISTRACTION INSIDE THE VEHICLE 8 - OTHER DISTRACTION OUTSIDE THE VEHICLE 9 - OTHER / UNKNOWN | 1 - NONE GIVEN 2 - TEST REFUSED 3 - TEST GIVEN, CONTAMINATED SAMPLE / UNUSABLE 4 - TEST GIVEN, RESULTS KNOWN 5 - TEST GIVEN, RESULTS UNKNOWN |
| INJURED TAKEN BY | EJECTION | TRAPPED | OL ENDORSEMENT | CONDITION | ALCOHOL TEST TYPE | DRUG TEST TYPE |
| 1 - NOT TRANSPORTED / TREATED AT SCENE 2 - EMS 3 - POLICE 9 - OTHER / UNKNOWN | 1 - NOT EJECTED 2 - PARTIALLY EJECTED 3 - TOTALLY EJECTED 4 - NOT APPLICABLE | 1 - NOT TRAPPED 2 - EXTRICATED BY MECHANICAL MEANS 3 - FREED BY NON-MECHANICAL MEANS | H - HAZMAT M - MOTORCYCLE P - PASSENGER N - TANKER Q - MOTOR SCOOTER R - THREE-WHEEL MOTORCYCLE S - SCHOOL BUS T - DOUBLE & TRIPLE TRAILERS X - TANKER / HAZMAT | 1 - APPARENTLY NORMAL 2 - PHYSICAL IMPAIRMENT 3 - EMOTIONAL (E.G., DEPRESSED, ANGRY, DISTURBED) 4 - ILLNESS 5 - FELL ASLEEP, FAINTED, FATIGUED, ETC. 6 - UNDER THE INFLUENCE OF MEDICATIONS / DRUGS / ALCOHOL 9 - OTHER / UNKNOWN | 1 - NONE 2 - BLOOD 3 - URINE 4 - BREATH 5 - OTHER | 1 - NONE 2 - BLOOD 3 - URINE 4 - OTHER |
| SAFETY EQUIPMENT | TRAPPED | TRAPPED | GENDER | CONDITION | DRUG TEST RESULT(S) | DRUG TEST RESULT(S) |
| 1 - NONE USED 2 - SHOULDER BELT ONLY USED 3 - LAP BELT ONLY USED 4 - SHOULDER & LAP BELT USED 5 - CHILD RESTRAINT SYSTEM - FORWARD FACING 6 - CHILD RESTRAINT SYSTEM - REAR FACING 7 - BOOSTER SEAT 8 - HELMET USED 9 - PROTECTIVE PADS USED (ELBOW, KNEES, ETC.) 10 - REFLECTIVE CLOTHING 11 - LIGHTING - PEDESTRIAN / BICYCLE ONLY 99 - OTHER / UNKNOWN | 1 - NOT TRAPPED 2 - EXTRICATED BY MECHANICAL MEANS 3 - FREED BY NON-MECHANICAL MEANS | 1 - NOT TRAPPED 2 - EXTRICATED BY MECHANICAL MEANS 3 - FREED BY NON-MECHANICAL MEANS | F - FEMALE M - MALE U - OTHER / UNKNOWN | 1 - APPARENTLY NORMAL 2 - PHYSICAL IMPAIRMENT 3 - EMOTIONAL (E.G., DEPRESSED, ANGRY, DISTURBED) 4 - ILLNESS 5 - FELL ASLEEP, FAINTED, FATIGUED, ETC. 6 - UNDER THE INFLUENCE OF MEDICATIONS / DRUGS / ALCOHOL 9 - OTHER / UNKNOWN | 1 - NONE 2 - BLOOD 3 - URINE 4 - OTHER | 1 - AMPHETAMINES 2 - BARBITURATES 3 - BENZODIAZEPINES 4 - CANNABINOIDS 5 - COCAINE 6 - OPIATES / OPIOIDS 7 - OTHER 8 - NEGATIVE RESULTS |



MOTORIST / Non-MOTORIST

LOCAL REPORT NUMBER
2 0 2 2 - 0 0 0 2 0 0 9 5

| | | | | |
|--|--|---|-------------------|--------------------|
| UNIT # 0 4 | NAME: LAST, FIRST, MIDDLE HUNT, COLLIN, RAMSEY | DATE OF BIRTH 0 1 2 6 2 0 0 4 | AGE 1 8 | GENDER M |
| ADDRESS: STREET, CITY, STATE, ZIP 9 MARY ST, RITTMAN, OH 44270 | | CONTACT PHONE - INCLUDE AREA CODE | | |

| | | | | | | | | | |
|-----------------------|----------------------------|----------------------------|---|--|--|--------------------------------|---|----------------------|---|
| INJURIES 5 | INJURED TAKEN BY | EMS AGENCY (NAME) | INJURED TAKEN TO: MEDICAL FACILITY (NAME, CITY) | SAFETY EQUIPMENT USED 0 4 | <input type="checkbox"/> DOT-COMPLIANT MC HELMET | SEATING POSITION 0 1 | AIR BAG USAGE 1 | EJECTION 1 | TRAPPED 1 |
| OL STATE OH | OPERATOR LICENSE NUMBER | | OFFENSE CHARGED | LOCAL CODE <input type="checkbox"/> | OFFENSE DESCRIPTION | | CITATION NUMBER | | |
| OL CLASS 4 | ENDORSEMENT SELECT UP TO 2 | RESTRICTION SELECT UP TO 3 | DRIVER DISTRACTED BY 1 | ALCOHOL / DRUG SUSPECTED <input type="checkbox"/> ALCOHOL <input type="checkbox"/> MARIJUANA <input type="checkbox"/> OTHER DRUG | | CONDITION 1 | ALCOHOL TEST STATUS TYPE VALUE STATUS TYPE RESULT SELECT UP TO 4 1 1 | | DRUG TEST(S) STATUS TYPE RESULT SELECT UP TO 4 1 1 |

| | | | | |
|-----------------------------------|---------------------------|-----------------------------------|-----|--------|
| UNIT # | NAME: LAST, FIRST, MIDDLE | DATE OF BIRTH | AGE | GENDER |
| ADDRESS: STREET, CITY, STATE, ZIP | | CONTACT PHONE - INCLUDE AREA CODE | | |

| | | | | | | | | | |
|----------|----------------------------|----------------------------|---|--|--|------------------|---|----------|---|
| INJURIES | INJURED TAKEN BY | EMS AGENCY (NAME) | INJURED TAKEN TO: MEDICAL FACILITY (NAME, CITY) | SAFETY EQUIPMENT USED | <input type="checkbox"/> DOT-COMPLIANT MC HELMET | SEATING POSITION | AIR BAG USAGE | EJECTION | TRAPPED |
| OL STATE | OPERATOR LICENSE NUMBER | | OFFENSE CHARGED | LOCAL CODE <input type="checkbox"/> | OFFENSE DESCRIPTION | | CITATION NUMBER | | |
| OL CLASS | ENDORSEMENT SELECT UP TO 2 | RESTRICTION SELECT UP TO 3 | DRIVER DISTRACTED BY | ALCOHOL / DRUG SUSPECTED <input type="checkbox"/> ALCOHOL <input type="checkbox"/> MARIJUANA <input type="checkbox"/> OTHER DRUG | | CONDITION | ALCOHOL TEST STATUS TYPE VALUE STATUS TYPE RESULT SELECT UP TO 4 | | DRUG TEST(S) STATUS TYPE RESULT SELECT UP TO 4 |

| | | | | |
|-----------------------------------|---------------------------|-----------------------------------|-----|--------|
| UNIT # | NAME: LAST, FIRST, MIDDLE | DATE OF BIRTH | AGE | GENDER |
| ADDRESS: STREET, CITY, STATE, ZIP | | CONTACT PHONE - INCLUDE AREA CODE | | |

| | | | | | | | | | |
|----------|----------------------------|----------------------------|---|--|--|------------------|---|----------|---|
| INJURIES | INJURED TAKEN BY | EMS AGENCY (NAME) | INJURED TAKEN TO: MEDICAL FACILITY (NAME, CITY) | SAFETY EQUIPMENT USED | <input type="checkbox"/> DOT-COMPLIANT MC HELMET | SEATING POSITION | AIR BAG USAGE | EJECTION | TRAPPED |
| OL STATE | OPERATOR LICENSE NUMBER | | OFFENSE CHARGED | LOCAL CODE <input type="checkbox"/> | OFFENSE DESCRIPTION | | CITATION NUMBER | | |
| OL CLASS | ENDORSEMENT SELECT UP TO 2 | RESTRICTION SELECT UP TO 3 | DRIVER DISTRACTED BY | ALCOHOL / DRUG SUSPECTED <input type="checkbox"/> ALCOHOL <input type="checkbox"/> MARIJUANA <input type="checkbox"/> OTHER DRUG | | CONDITION | ALCOHOL TEST STATUS TYPE VALUE STATUS TYPE RESULT SELECT UP TO 4 | | DRUG TEST(S) STATUS TYPE RESULT SELECT UP TO 4 |

| INJURIES | SEATING POSITION | AIR BAG | OL CLASS | OL RESTRICTION(S) | DRIVER DISTRACTION | TEST STATUS |
|---|--|---|--|---|--|--|
| 1 - FATAL 2 - SUSPECTED SERIOUS INJURY 3 - SUSPECTED MINOR INJURY 4 - POSSIBLE INJURY 5 - NO APPARENT INJURY | 1 - FRONT - LEFT SIDE (MOTORCYCLE DRIVER) 2 - FRONT - MIDDLE 3 - FRONT - RIGHT SIDE 4 - SECOND - LEFT SIDE (MOTORCYCLE PASSENGER) 5 - SECOND - MIDDLE 6 - SECOND - RIGHT SIDE 7 - THIRD - LEFT SIDE (MOTORCYCLE SIDE CAR) 8 - THIRD - MIDDLE 9 - THIRD - RIGHT SIDE 10 - SLEEPER SECTION OF TRUCK CAB | 1 - NOT DEPLOYED 2 - DEPLOYED FRONT 3 - DEPLOYED SIDE 4 - DEPLOYED BOTH FRONT / SIDE 5 - NOT APPLICABLE 9 - DEPLOYMENT UNKNOWN | 1 - CLASS A 2 - CLASS B 3 - CLASS C 4 - REGULAR CLASS (OHIO = D) 5 - MC MOPED ONLY 6 - NO VALID OL | 1 - ALCOHOL INTERLOCK DEVICE 2 - CDL INTRASTATE ONLY 3 - CORRECTIVE LENSES 4 - FARM WAIVER 5 - EXCEPT CLASS A BUS 6 - EXCEPT CLASS A & CLASS B BUS 7 - EXCEPT TRACTOR-TRAILER 8 - INTERMEDIATE LICENSE RESTRICTIONS 9 - LEARNER'S PERMIT RESTRICTIONS 10 - LIMITED TO DAYLIGHT ONLY 11 - LIMITED TO EMPLOYMENT 12 - LIMITED - OTHER 13 - MECHANICAL DEVICES (SPECIAL BRAKES, HAND CONTROLS, OR OTHER ADAPTIVE DEVICES) 14 - MILITARY VEHICLES ONLY 15 - MOTOR VEHICLES WITHOUT AIR BRAKES 16 - OUTSIDE MIRROR 17 - PROSTHETIC AID 18 - OTHER | 1 - NOT DISTRACTED 2 - MANUALLY OPERATING AN ELECTRONIC COMMUNICATION DEVICE (TEXTING, TYPING, DIALING) 3 - TALKING ON HANDS-FREE COMMUNICATION DEVICE 4 - TALKING ON HAND-HELD COMMUNICATION DEVICE 5 - OTHER ACTIVITY WITH AN ELECTRONIC DEVICE 6 - PASSENGER 7 - OTHER DISTRACTION INSIDE THE VEHICLE 8 - OTHER DISTRACTION OUTSIDE THE VEHICLE 9 - OTHER / UNKNOWN | 1 - NONE GIVEN 2 - TEST REFUSED 3 - TEST GIVEN, CONTAMINATED SAMPLE / UNUSABLE 4 - TEST GIVEN, RESULTS KNOWN 5 - TEST GIVEN, RESULTS UNKNOWN |
| INJURED TAKEN BY 1 - NOT TRANSPORTED / TREATED AT SCENE 2 - EMS 3 - POLICE 9 - OTHER / UNKNOWN | | EJECTION 1 - NOT EJECTED 2 - PARTIALLY EJECTED 3 - TOTALLY EJECTED 4 - NOT APPLICABLE | OL ENDORSEMENT H - HAZMAT M - MOTORCYCLE P - PASSENGER N - TANKER Q - MOTOR SCOOTER R - THREE-WHEEL MOTORCYCLE S - SCHOOL BUS T - DOUBLE & TRIPLE TRAILERS X - TANKER / HAZMAT | | | ALCOHOL TEST TYPE 1 - NONE 2 - BLOOD 3 - URINE 4 - BREATH 5 - OTHER |
| SAFETY EQUIPMENT 1 - NONE USED 2 - SHOULDER BELT ONLY USED 3 - LAP BELT ONLY USED 4 - SHOULDER & LAP BELT USED 5 - CHILD RESTRAINT SYSTEM - FORWARD FACING 6 - CHILD RESTRAINT SYSTEM - REAR FACING 7 - BOOSTER SEAT 8 - HELMET USED 9 - PROTECTIVE PADS USED (ELBOW, KNEES, ETC.) 10 - REFLECTIVE CLOTHING 11 - LIGHTING - PEDESTRIAN / BICYCLE ONLY 99 - OTHER / UNKNOWN | 11 - PASSENGER IN OTHER ENCLOSED CARGO AREA (NON-TRAILING UNIT, BUS, PICK-UP WITH CAP) 12 - PASSENGER IN UNENCLOSED CARGO AREA 13 - TRAILING UNIT 14 - RIDING ON VEHICLE EXTERIOR (NON-TRAILING UNIT) 15 - NON-MOTORIST 99 - OTHER / UNKNOWN | TRAPPED 1 - NOT TRAPPED 2 - EXTRICATED BY MECHANICAL MEANS 3 - FREED BY NON-MECHANICAL MEANS | GENDER F - FEMALE M - MALE U - OTHER / UNKNOWN | | CONDITION 1 - APPARENTLY NORMAL 2 - PHYSICAL IMPAIRMENT 3 - EMOTIONAL (E.G., DEPRESSED, ANGRY, DISTURBED) 4 - ILLNESS 5 - FELL ASLEEP, FAINTED, FATIGUED, ETC. 6 - UNDER THE INFLUENCE OF MEDICATIONS / DRUGS / ALCOHOL 9 - OTHER / UNKNOWN | DRUG TEST TYPE 1 - NONE 2 - BLOOD 3 - URINE 4 - OTHER |
| | | | | | | DRUG TEST RESULT(S) 1 - AMPHETAMINES 2 - BARBITURATES 3 - BENZODIAZEPINES 4 - CANNABINOIDS 5 - COCAINE 6 - OPIATES / OPIOIDS 7 - OTHER 8 - NEGATIVE RESULTS |



OCCUPANT / WITNESS ADDENDUM

LOCAL REPORT NUMBER
 2 0 2 2 - 0 0 0 2 0 0 9 5

| | | | | | | | | | | |
|----------|--|---|----------------------------------|---|------------------------------|--|-------------------------|--------------------|---------------|--------------|
| OCCUPANT | UNIT # 02 | NAME: LAST, FIRST, MIDDLE TELL, JACQUELYN, PIPER | DATE OF BIRTH 1 1 1 9 2 0 0 1 | AGE 21 | GENDER F | | | | | |
| | ADDRESS: STREET, CITY, STATE, ZIP 139 ELM ST ,GRANVILLE ,OH 43023 | | | CONTACT PHONE - INCLUDE AREA CODE | | | | | | |
| | INJURIES 5 | INJURED TAKEN BY | EMS Agency (NAME) | INJURED TAKEN TO: MEDICAL FACILITY (NAME, CITY) | SAFETY EQUIPMENT USED 0 4 | <input type="checkbox"/> DOT-COMPLIANT MC HELMET | SEATING POSITION 0 3 | AIR BAG USAGE 1 | EJECTION 1 | TRAPPED 1 |

| | | | | | | | | | | |
|----------|---|--|----------------------------------|---|------------------------------|--|-------------------------|--------------------|---------------|--------------|
| OCCUPANT | UNIT # 02 | NAME: LAST, FIRST, MIDDLE TREPAL, TIMOTHY, JOHN | DATE OF BIRTH 0 3 1 9 2 0 0 4 | AGE 18 | GENDER M | | | | | |
| | ADDRESS: STREET, CITY, STATE, ZIP 1737 SUNVIEW RD ,LYNDHURST ,OH 44124 | | | CONTACT PHONE - INCLUDE AREA CODE | | | | | | |
| | INJURIES 5 | INJURED TAKEN BY | EMS Agency (NAME) | INJURED TAKEN TO: MEDICAL FACILITY (NAME, CITY) | SAFETY EQUIPMENT USED 0 4 | <input type="checkbox"/> DOT-COMPLIANT MC HELMET | SEATING POSITION 0 4 | AIR BAG USAGE 1 | EJECTION 1 | TRAPPED 1 |

| | | | | | | | | | | |
|----------|--|--|----------------------------------|---|------------------------------|--|-------------------------|--------------------|---------------|--------------|
| OCCUPANT | UNIT # 02 | NAME: LAST, FIRST, MIDDLE CONROY, MARIBEL, JANE | DATE OF BIRTH 0 8 2 7 2 0 0 4 | AGE 18 | GENDER F | | | | | |
| | ADDRESS: STREET, CITY, STATE, ZIP 10017 BROADVIEW RD ,BROADVIEW HTS ,OH 44147 | | | CONTACT PHONE - INCLUDE AREA CODE | | | | | | |
| | INJURIES 5 | INJURED TAKEN BY | EMS Agency (NAME) | INJURED TAKEN TO: MEDICAL FACILITY (NAME, CITY) | SAFETY EQUIPMENT USED 0 4 | <input type="checkbox"/> DOT-COMPLIANT MC HELMET | SEATING POSITION 0 5 | AIR BAG USAGE 1 | EJECTION 1 | TRAPPED 1 |

| | | | | | | | | | | |
|----------|--|---|----------------------------------|---|------------------------------|--|-------------------------|--------------------|---------------|--------------|
| OCCUPANT | UNIT # 02 | NAME: LAST, FIRST, MIDDLE BACH, JOSHUA, CARTER | DATE OF BIRTH 0 5 1 7 2 0 0 2 | AGE 20 | GENDER M | | | | | |
| | ADDRESS: STREET, CITY, STATE, ZIP 843 LONGBROOK DR ,WADSWORTH ,OH 44281 | | | CONTACT PHONE - INCLUDE AREA CODE | | | | | | |
| | INJURIES 5 | INJURED TAKEN BY | EMS Agency (NAME) | INJURED TAKEN TO: MEDICAL FACILITY (NAME, CITY) | SAFETY EQUIPMENT USED 0 4 | <input type="checkbox"/> DOT-COMPLIANT MC HELMET | SEATING POSITION 0 6 | AIR BAG USAGE 1 | EJECTION 1 | TRAPPED 1 |

| INJURIES | SAFETY EQUIPMENT USED | SEATING POSITION | AIR BAG USAGE |
|--|---|--|------------------------------------|
| 1 - FATAL | 1 - NONE USED - VEHICLE OCCUPANT | 1 - FRONT - LEFT SIDE (MOTORCYCLE DRIVER) | 1 - NOT DEPLOYED |
| 2 - SUSPECTED SERIOUS INJURY | 2 - SHOULDER BELT ONLY USED | 2 - FRONT - MIDDLE | 2 - DEPLOYED FRONT |
| 3 - SUSPECTED MINOR INJURY | 3 - LAP BELT ONLY USED | 3 - FRONT - RIGHT SIDE | 3 - DEPLOYED SIDE |
| 4 - POSSIBLE INJURY | 4 - SHOULDER & LAP BELT USED | 4 - SECOND - LEFT SIDE (MOTORCYCLE PASSENGER) | 4 - DEPLOYED BOTH FRONT/SIDE |
| 5 - NO APPARENT INJURY | 5 - CHILD RESTRAINT SYSTEM - FORWARD FACING | 5 - SECOND - MIDDLE | 5 - NOT APPLICABLE |
| INJURED TAKEN BY | | 6 - SECOND - RIGHT SIDE | 9 - DEPLOYMENT UNKNOWN |
| 1 - NOT TRANSPORTED / TREATED AT SCENE | 6 - CHILD RESTRAINT SYSTEM - REAR FACING | 7 - THIRD - LEFT SIDE (MOTORCYCLE SIDE CAR) | EJECTION |
| 2 - EMS | 7 - BOOSTER SEAT | 8 - THIRD - MIDDLE | 1 - NOT EJECTED |
| 3 - POLICE | 8 - HELMET USED | 9 - THIRD - RIGHT SIDE | 2 - PARTIALLY EJECTED |
| 9 - OTHER / UNKNOWN | 9 - PROTECTIVE PADS USED (ELBOW, KNEES, ETC.) | 10 - SLEEPER SECTION OF TRUCK CAB | 3 - TOTALLY EJECTED |
| GENDER | | 11 - PASSENGER IN OTHER ENCLOSED CARGO AREA (NON-TRAILING UNIT, BUS, PICK-UP WITH CAP) | 4 - NOT APPLICABLE |
| F - FEMALE | 10 - REFLECTIVE CLOTHING | 12 - PASSENGER IN UNENCLOSED CARGO AREA | TRAPPED |
| M - MALE | 11 - LIGHTING - PEDESTRIAN / BICYCLE ONLY | 13 - TRAILING UNIT | 1 - NOT TRAPPED |
| U - OTHER / UNKNOWN | 99 - OTHER / UNKNOWN | 14 - RIDING ON VEHICLE EXTERIOR (NON-TRAILING UNIT) | 2 - EXTRICATED BY MECHANICAL MEANS |
| | | 15 - NON-MOTORIST | 3 - FREED BY NON-MECHANICAL MEANS |
| | | 99 - OTHER / UNKNOWN | |

| | | | | |
|---------|-----------------------------------|-----------------------------------|-----|--------|
| WITNESS | NAME: LAST, FIRST, MIDDLE | DATE OF BIRTH | AGE | GENDER |
| | ADDRESS: STREET, CITY, STATE, ZIP | CONTACT PHONE - INCLUDE AREA CODE | | |

| | | | | |
|---------|-----------------------------------|-----------------------------------|-----|--------|
| WITNESS | NAME: LAST, FIRST, MIDDLE | DATE OF BIRTH | AGE | GENDER |
| | ADDRESS: STREET, CITY, STATE, ZIP | CONTACT PHONE - INCLUDE AREA CODE | | |

| | | | | |
|---------|-----------------------------------|-----------------------------------|-----|--------|
| WITNESS | NAME: LAST, FIRST, MIDDLE | DATE OF BIRTH | AGE | GENDER |
| | ADDRESS: STREET, CITY, STATE, ZIP | CONTACT PHONE - INCLUDE AREA CODE | | |